

A.D. MMXXIII

OUTDOOR PAVINGS



a brand of Gambini Group SpA

+ plus
OUTDOOR PAVINGS

+ plus
OUTDOOR PAVINGS



GENERAL



COLLECTIONS

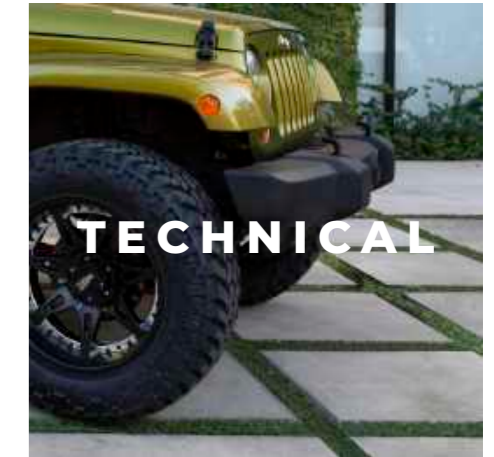

TECHNICAL

LE COLLEZIONI collections _____ p.4	ASGARD _____ p.10	TRIM PIECES _____ p.76
INDICE PER FORMATO index of sizes _____ p.6	BET _____ p.16	PISCINE swimming pools & solarium _____ p.78
DESTINAZIONI D'USO Destination uses _____ p.7	BLUE LABEL _____ p. 24	SCALE steps & stairways _____ p.82
I VANTAGGI DI +plus Advantages _____ p.8	BORDEAUX _____ p.30	ARREDI furnitures & fittings _____ p.84
	HEMISPHERE _____ p.36	COPERTINE copings _____ p.88
	MATERIA _____ p.44	GRIGLIE PER ALBERI Tree Grid _____ p.90
	OCEAN BLACK _____ p.50	SISTEMI DI POSA Installation systems _____ p.92
	TREVI _____ p.56	INDICAZIONI DI POSA Laying instructions _____ p.96
	UNIKA _____ p.62	IMBALLI E PESI Packing and weights _____ p.97
	XO _____ p.68	CARATTERISTICHE TECNICHE Technical specifications _____ p.98
		CONDIZIONI GENERALI DI VENDITA General terms & conditions of sale _____ p.99

LA GAMMA +plus collections



EFFETTO PIETRA stone effect

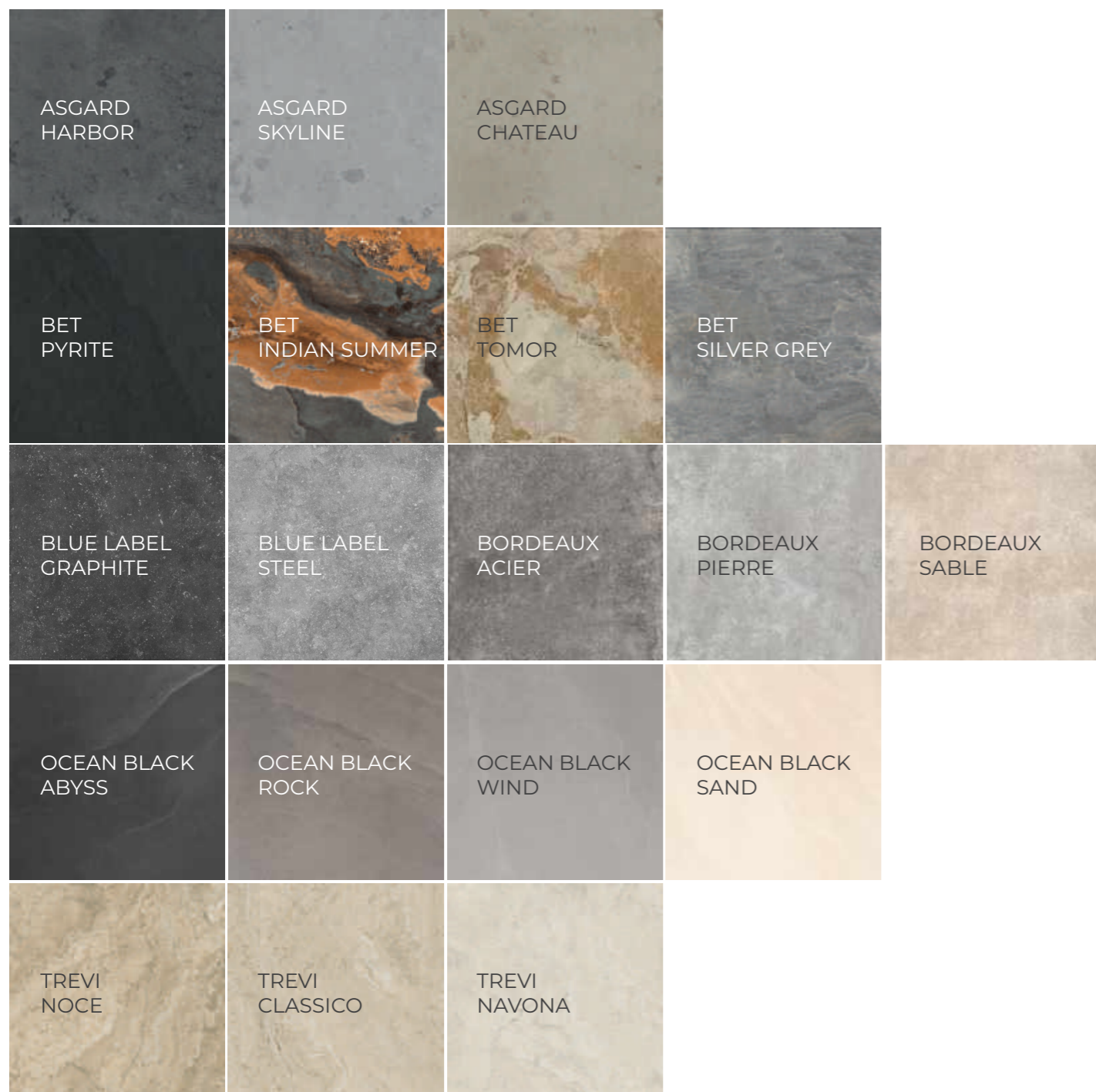

EFFETTO CEMENTO concrete effect



EFFETTO METALLO metal effect

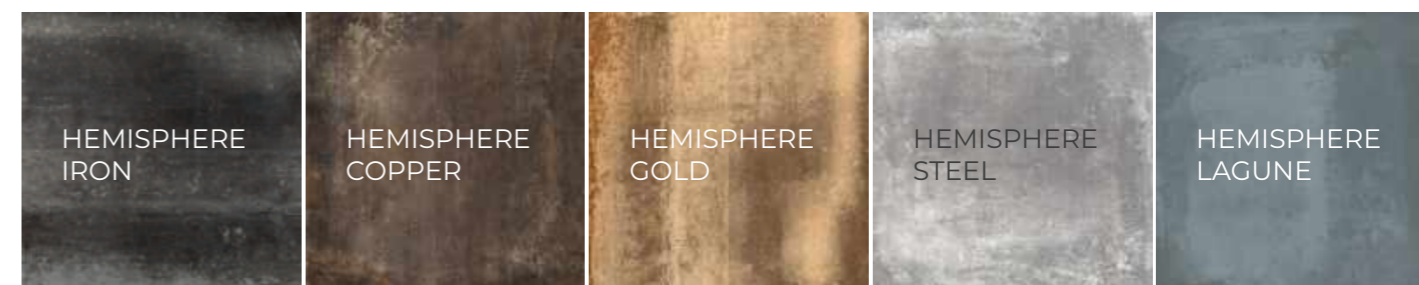

INDICE PER FORMATO index of sizes

FORMATO 80x80 RET . SIZE 32"x32"

20mm

BLUE LABEL P.24
HEMISPHERE p.36
TREVI p.56
UNIKA p.62
XO p.68

30mm

UNIKA p.62
XO p.68



FORMATO 60x90 RET . SIZE 24"x36"

20mm

BET p.16
BORDEAUX p.30
OCEAN BLACK p.50
XO p.68

30mm

UNIKA p.62
XO p.68

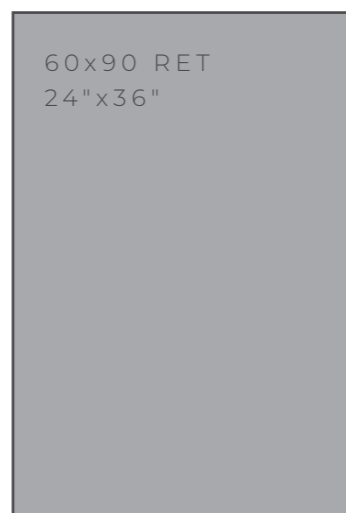

FORMATO 60x60 RET . SIZE 24"x24"

20mm

ASGARD p.10
BET p.16
HEMISPHERE p.36
MATERIA p.44
OCEAN BLACK p.50
UNIKA p.62
XO p.68

30mm

UNIKA p.62
XO p.68



DESTINAZIONI D'USO destination uses



Piscine . Pools

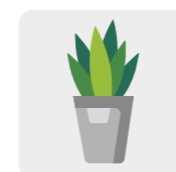

Giardini . Gardens

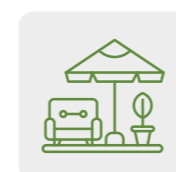

Terrazze . Terraces



Spazi pubblici .
Public spaces



I VANTAGGI

advantages



INGELIVO
FROST
RESISTANT



RESISTENTE AGLI
SBALZI TERMICI
RESISTANT TO SUDDEN
TEMPERATURE
CHANGES



RESISTENTE
AI SALI
RESISTANT TO
SALT



RESISTENTE A ACIDI/
PRODOTTI CHIMICI
RESISTANT TO
ACID AND CHEMICALS



RESISTENTE A
MUFFE E MUSCHI
RESISTANT TO DAMAGE
FROM MOULD AND MOSS



ANTISCIVOLO
ANTISLIP



INASSORBENTE
IMPERVIOUS



COLORI RESISTENTI
NEL TEMPO
LONG-LASTING
COLOURS



POSA FACILE
E VELOCE
QUICK AND EASY
TO INSTALL



FACILMENTE
REMOVIBILE
EASY TO
REMOVE



RIUTILIZZABILE
REUSABLE



LUNGHISSIMA
DURATA NEL TEMPO
EXTREMELY
LONG-LASTING
DURABILITY



ISPEZIONABILE
READLY
SERVICEABLE



PERMETTE ANCHE
POSA CON COLLA
INSTALLATION WITH
ADHESIVE IS POSSIBLE



ALTAMENTE RESISTENTE
AI CARICHI
HIGHLY RESISTANT
TO LOADS



AMPIA GAMMA
DI FINITURE
WIDE RANGE OF
FINISHES



PERMETTE IL DEFLUSSO
DELL'ACQUA
ALLOWS WATER
DRAINAGE



FACILE DA PULIRE
EASY TO CLEAN



ASGARD

+ plus
OUTDOOR PAVINGS



skyline 60x60 cm Rettificato . 24"x24" Rectified



EFFETTO PIETRA

"L'eccezionale durezza e resistenza della pietra ha ispirato la creazione di questa linea, realizzata in tre differenti colori che esaltano un aspetto autentico dalla superficie morbida. Tutti gli elementi presenti in natura vivono in questa serie dal nome mitologico legato alla cultura e tradizione norrena ASGARD: dove vivono gli Dei."

STONE EFFECT

"The exceptional durability and resistance of the stone inspired the creation of this series, made in three different colors, that enhance an authentic appearance with a soft surface. All the elements present in nature live in this series with a mythological name, culture linked to Norse culture and traditions. Asgard: where Gods live."



Piscine
Pools



Giardini
Gardens



Terrazze
Terraces



Spazi pubblici
Public spaces



chateau 60x60 cm Rettificato . 24"x24" Rectified



harbor 60x60 cm Rettificato . 24"x24" Rectified

ASGARD

EFFETTO PIETRA
STONE EFFECT

GRES PORCELLANATO IMPASTO COLORATO.
COLORED BODY PORCELAIN STONEWARE.

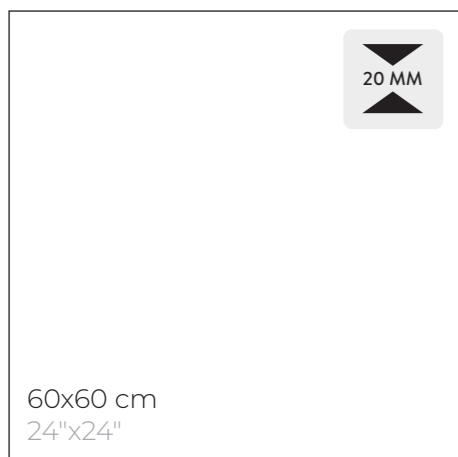

Disponibile nello spessore 1 cm
Available in thickness 1 cm

 CATALOGO GENERALE GTOT
CATALOGO ASGARD

SPECIAL SHAPES FORME SPECIALI

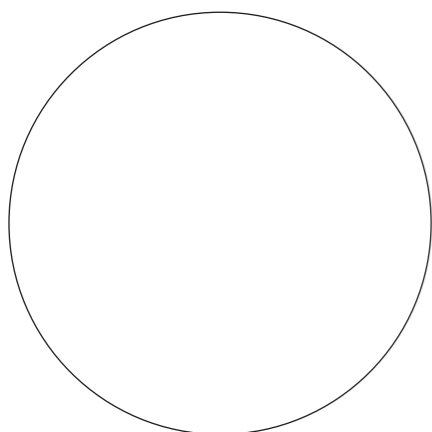

BUBBLE_60

56x56 cm
24"x24"



chateau



60x60 cm Rettificato
24"x24" Rectified

skyline

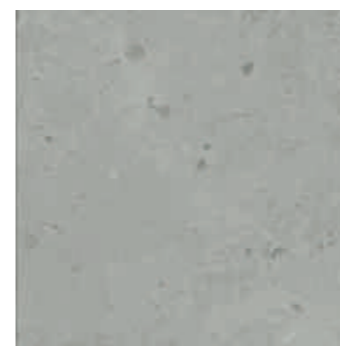

60x60 cm Rettificato
24"x24" Rectified

harbor

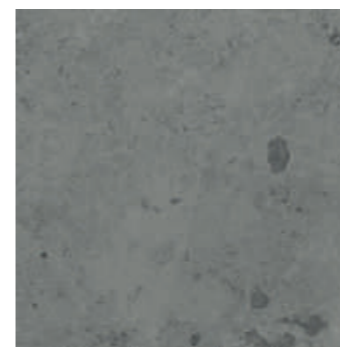

60x60 cm Rettificato
24"x24" Rectified

* LE FORME SPECIALI "ON DEMAND"
VENGONO REALIZZATI SOLO SU RICHIESTA
CON CONSEGNA 6 SETTIMANE.
SPECIAL SHAPES "ON DEMAND" ARE AVAILABLE ONLY
ON REQUEST AND HAVE A 6-WEEK LEAD-TIME.

B E T

+ plus
OUTDOOR PAVINGS



t o m o r 60x90 cm Rettificato . 24"x36" Rectified



EFFETTO PIETRA

"Caleidoscopica come l'estate indiana, micacea come il metallo, la forza espressiva della pietra unita alla resistenza tecnica del grès porcellanato. Il pavimento che assicura performances tecniche insuperabili per progettare esterni unici destinati a durare nel tempo."

STONE EFFECT

"Kaleidoscopic like the indian summer, micaceous like the metal, the significant strength of the stone along with the technical resistance of the porcelain stoneware. A collection granting technical performances to design unique exterior spaces for lifetime duration."



Piscine
Pools



Giardini
Gardens

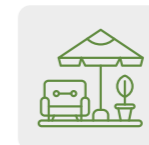

Terrazze
Terraces



Spazi pubblici
Public spaces



indian summer cloud_90



silver grey 60x60 cm Rettificato . 24"x24" Rectified



Piscine
Pools



Giardini
Gardens

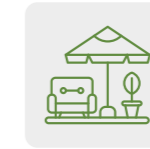

Terrazze
Terraces



Spazi pubblici
Public spaces



indian summer 60x60 cm Rettificato . 24"x24" Rectified



pyrite 60x60 cm Rettificato . 24"x24" Rectified

BET

EFFETTO PIETRA
STONE EFFECT

GRES PORCELLANATO IMPASTO COLORATO.
COLORED BODY PORCELAIN STONEWARE.

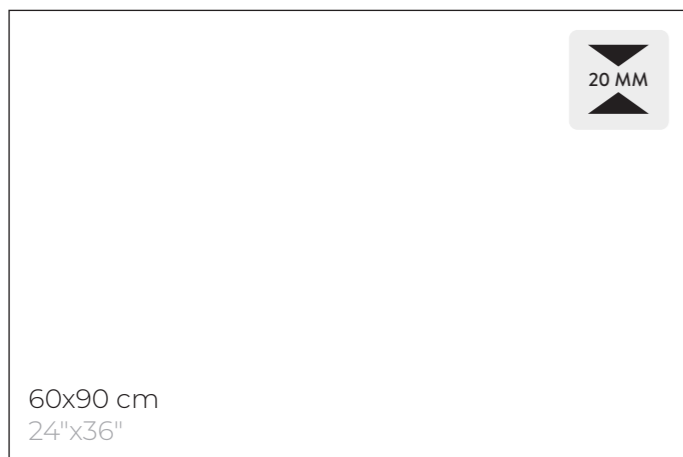

SPECIAL SHAPES
FORME SPECIALI

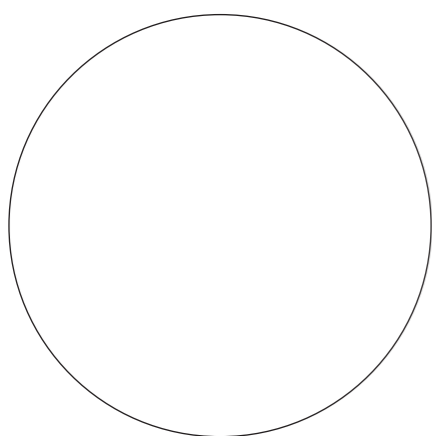

BUBBLE_60
56x56 cm
24"x24"

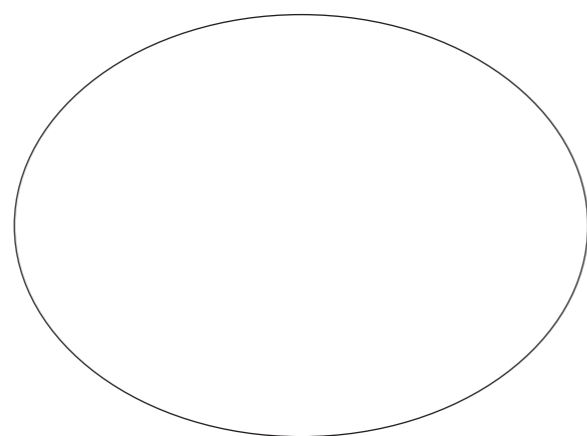

CLOUD_90
76x56 cm
32"x24"



Disponibile nello spessore 1 cm
Available in thickness 1 cm

CATALOGO GENERALE GTOT
CATALOGO BET

* LE FORME SPECIALI "ON DEMAND"
VENGONO REALIZZATI SOLO SU RICHIESTA
CON CONSEGNA 6 SETTIMANE.
SPECIAL SHAPES "ON DEMAND" ARE AVAILABLE ONLY
ON REQUEST AND HAVE A 6-WEEK LEAD-TIME.



indian summer



60x90 cm Rettificato
24"x36" Rectified



60x60 cm Rettificato
24"x24" Rectified

silver grey



60x90 cm Rettificato
24"x36" Rectified



60x60 cm Rettificato
24"x24" Rectified

pyrite

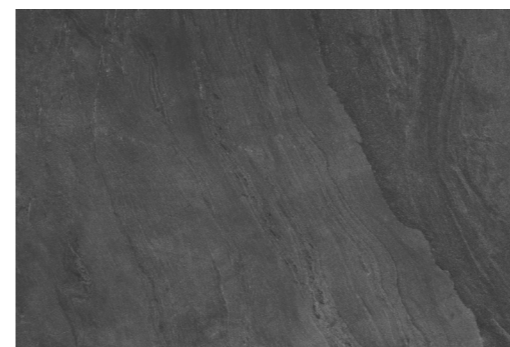

60x90 cm Rettificato
24"x36" Rectified



60x60 cm Rettificato
24"x24" Rectified

tomor



60x90 cm Rettificato
24"x36" Rectified



60x60 cm Rettificato
24"x24" Rectified

BLUE LABEL

+ plus
OUTDOOR PAVINGS



steel | 80x80 cm Rettificato . 32"x32" Rectified



EFFETTO PIETRA

Ispirati dalle antiche rocce metamorfiche e dal patrimonio artistico vallone, abbiamo creato PIERRE BLEU, una collezione che deriva il suo nome e le sue gradazioni di colore, dal grigio al nero, dalla pietra belga rivisitata e fortificata dalle caratteristiche di sostenibilità e durezza del gres porcellanato.

STONE EFFECT

Inspired by the ancient metamorphic rocks and the Walloon artistic heritage, we created PIERRE BLEU, a collection that derives its name and its gradations of color, from grey to black, from Belgian stone revisited and strengthened by the characteristics of sustainability and durability of porcelain stoneware.



Piscine
Pools



Giardini
Gardens

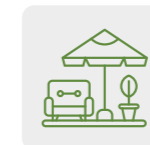

Terrazze
Terraces



Spazi pubblici
Public spaces



graphite 80x80 cm Rettificato . 32"x32" Rectified



graphite 80x80 cm Rettificato . 32"x32" Rectified

BLUE LABEL

EFFETTO PIETRA
STONE EFFECT

GRES PORCELLANATO IMPASTO COLORATO.
COLORED BODY PORCELAIN STONEWARE.

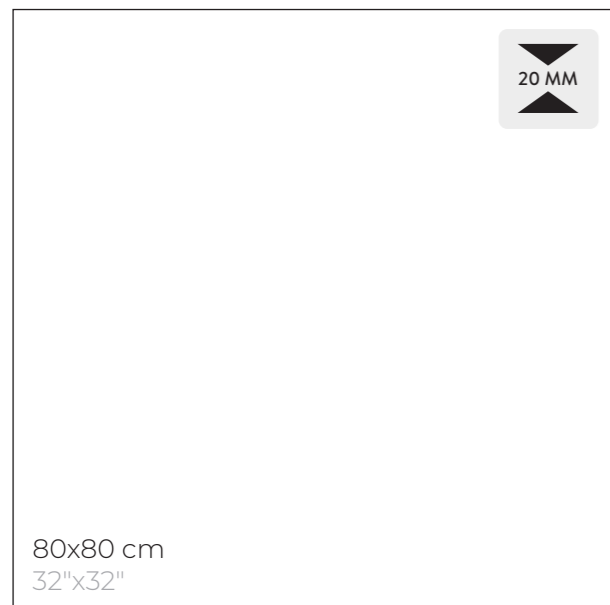

graphite



80x80 cm Rettificato
32"x32" Rectified

SPECIAL SHAPES
FORME SPECIALI

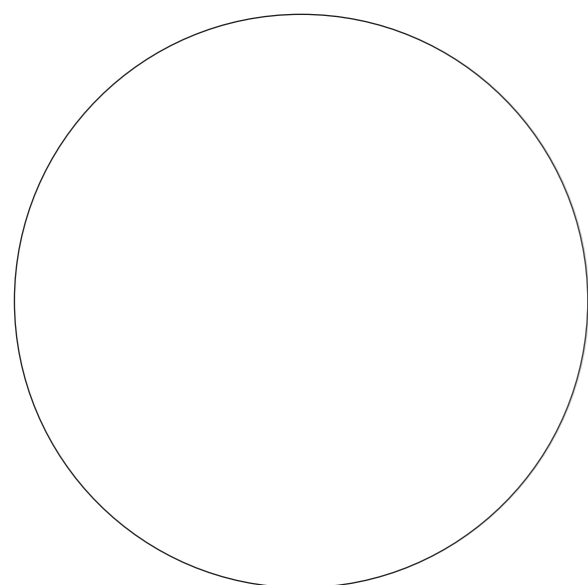

BUBBLE_80

76x76 cm
32"x32"

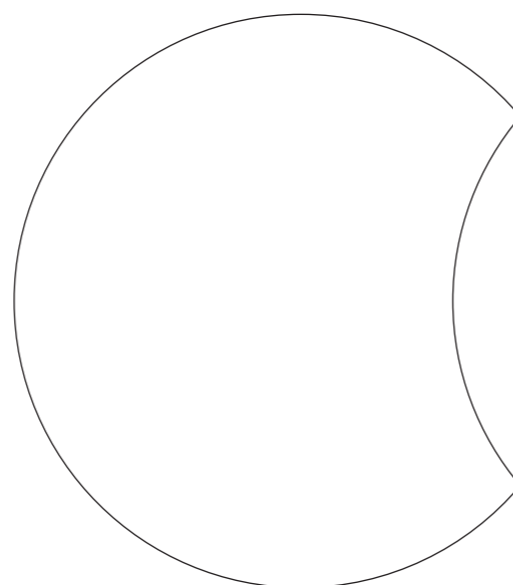

MOON_80

76x76 cm
32"x32"



steel



80x80 cm Rettificato
32"x32" Rectified

* LE FORME SPECIALI "ON DEMAND"
VENGONO REALIZZATI SOLO SU RICHIESTA
CON CONSEGNA 6 SETTIMANE.
SPECIAL SHAPES "ON DEMAND" ARE AVAILABLE ONLY
ON REQUEST AND HAVE A 6-WEEK LEAD-TIME.

BORDEAUX

+ plus
OUTDOOR PAVINGS



a c i e r 60x90 cm Rettificato . 24"x36" Rectified



EFFETTO PIETRA

Abbiamo attraversato i castelli della Aquitania e le navate di Saint Emilion, adottando il nome di una città e di un vino vellutato per dare vita a una pietra rustica ma elegantemente contemporanea: "Bordeaux una scelta senza tempo."

STONE EFFECT

Passing through Aquitaine castles and Saint Emilion naves, where a city and a smooth wine share the same name. It is this atmosphere that gives birth to a stone rustic and contemporary elegant at once: "Bordeaux a timeless choice."

sable 60x90 cm Rettificato . 24"x36" Rectified



pierre 60x90 cm Rettificato . 24"x36" Rectified



Piscine
Pools



Giardini
Gardens



Terrazze
Terraces



Spazi pubblici
Public spaces



sable 60x90 cm Rettificato . 24"x36" Rectified

BORDEAUX

EFFETTO PIETRA
STONE EFFECT

GRES PORCELLANATO IMPASTO COLORATO.
COLORED BODY PORCELAIN STONEWARE.

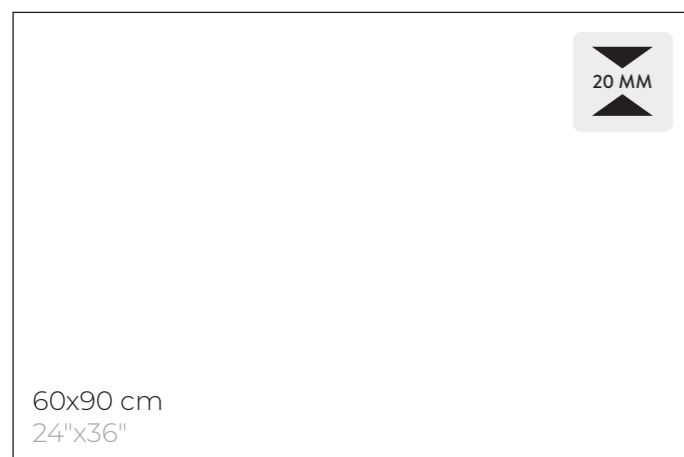

Disponibile nello spessore 1 cm
Available in thickness 1 cm



acier



60x90 cm Rettificato
24"x36" Rectified

pierre



60x90 cm Rettificato
24"x36" Rectified

sable



60x90 cm Rettificato
24"x36" Rectified

SPECIAL SHAPES
FORME SPECIALI

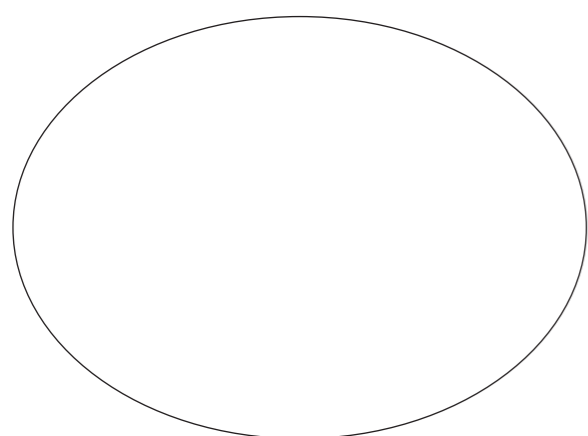

CLOUD_90

76x56 cm
32"x24"



* LE FORME SPECIALI "ON DEMAND"
VENGONO REALIZZATI SOLO SU RICHIESTA
CON CONSEGNA 6 SETTIMANE.
SPECIAL SHAPES "ON DEMAND" ARE AVAILABLE ONLY
ON REQUEST AND HAVE A 6-WEEK LEAD-TIME.

HEMISPHERE

+ plus
OUTDOOR PAVINGS



iron 60x60 cm Rettificato . 24"x24" Rectified



EFFETTO METALLO

"Miscela armoniosa tra metallo e cemento. Hemisphere: originale, moderna e versatile.."

METAL EFFECT

"Harmonious mix between metal and cement. Hemisphere: original, modern and versatile."



Piscine
Pools



Giardini
Gardens

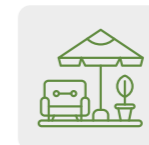

Terrazze
Terraces



Spazi pubblici
Public spaces

gold 60x60 cm Rettificato . 24"x24" Rectified



l a g u n e 60x60 cm Rettificato . 24"x24" Rectified



s t e e l 80x80 cm Rettificato . 32"x32" Rectified

HEMISPHERE

EFFETTO METALLO
METAL EFFECT

GRES PORCELLANATO IMPASTO COLORATO.
COLORED BODY PORCELAIN STONEWARE.



Disponibile nello spessore 1 cm
Available in thickness 1 cm

CATALOGO GENERALE GTOT
CATALOGO HEMISPHERE

QB UPEC.F+ 20 MM

U4 P3 E3 C2

80x80 cm
32"x32"

QB UPEC.F+ 20 MM

U4 P3 E3 C2

60x60 cm
24"x24"

iron



80x80 cm Rettificato
32"x32" Rectified

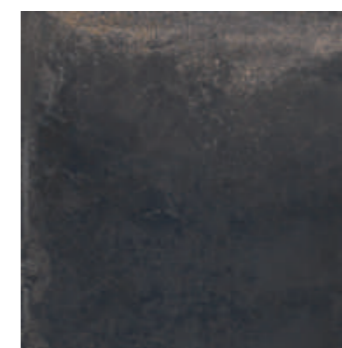

60x60 cm Rettificato
24"x24" Rectified

lagune



80x80 cm Rettificato
32"x32" Rectified



60x60 cm Rettificato
24"x24" Rectified

steel



80x80 cm Rettificato
32"x32" Rectified



60x60 cm Rettificato
24"x24" Rectified

SPECIAL SHAPES FORME SPECIALI

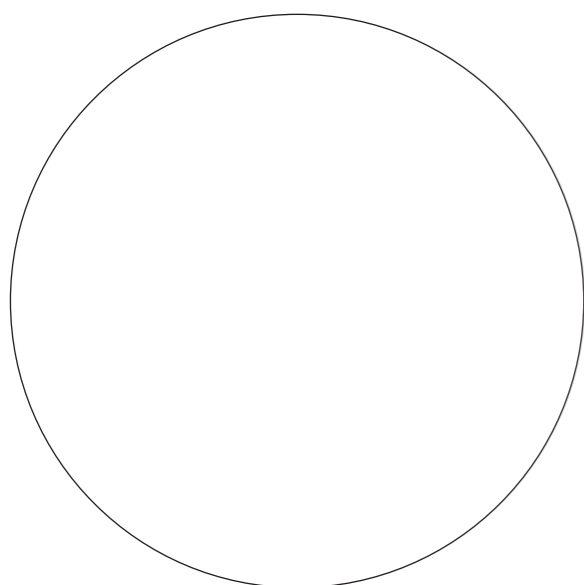

BUBBLE_80

76x76 cm
32"x32"

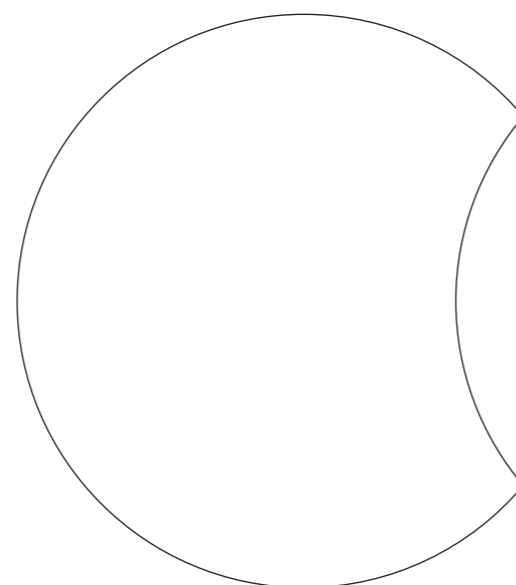

MOON_80

76x76 cm
32"x32"



BUBBLE_60

56x56 cm
24"x24"



* LE FORME SPECIALI "ON DEMAND"
VENGONO REALIZZATI SOLO SU RICHIESTA
CON CONSEGNA 6 SETTIMANE.
SPECIAL SHAPES "ON DEMAND" ARE AVAILABLE ONLY
ON REQUEST AND HAVE A 6-WEEK LEAD-TIME.

gold



80x80 cm Rettificato
32"x32" Rectified



60x60 cm Rettificato
24"x24" Rectified

copper



80x80 cm Rettificato
32"x32" Rectified



60x60 cm Rettificato
24"x24" Rectified



copper 80x80 cm Rettificato . 32"x32" Rectified

MATERIA

+ plus
OUTDOOR PAVINGS



grafite 60x60 cm Rettificato . 24"x24" Rectified

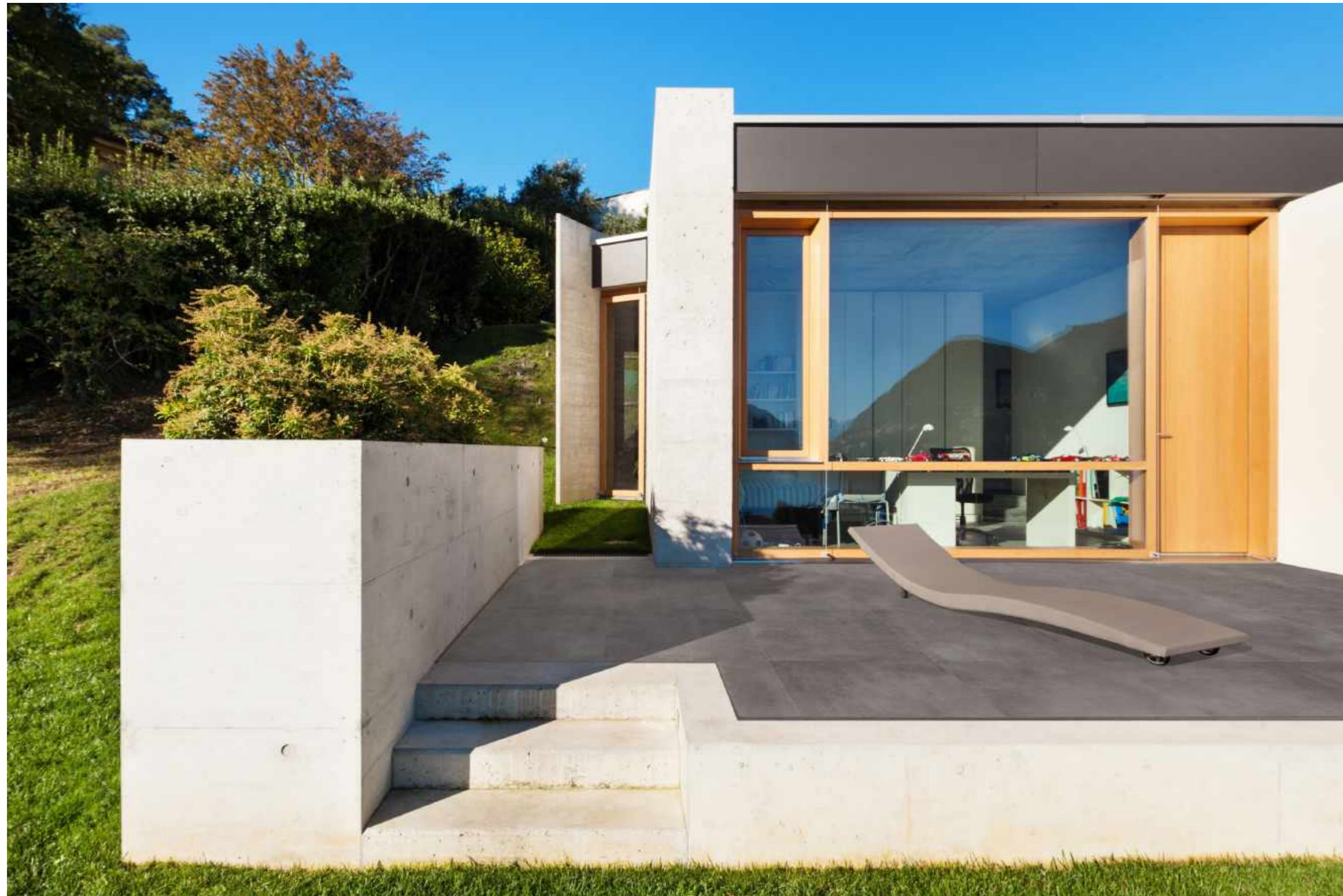

EFFETTO CEMENTO

«Una piastrella non è solo un pezzo di terra, è un rito che si ripete. Materia: la prendi, la ami, la condividi.»

CONCRETE EFFECT

A tile is not just a piece of clay, it is a ritual that is repeated.
Materia:
A collection to love and share.



Piscine
Pools



Giardini
Gardens

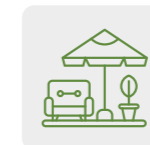

Terrazze
Terraces



Spazi pubblici
Public spaces

antracite 60x60 cm Rettificato . 24"x24" Rectified



beige 60x60 cm Rettificato . 24"x24" Rectified



grigio 60x60 cm Rettificato . 24"x24" Rectified

MATERIA

EFFETTO CEMENTO
CONCRETE EFFECT

GRES PORCELLANATO IMPASTO COLORATO.
COLORED BODY PORCELAIN STONEWARE.



QB UPEC.F+ 20 MM

U4 P3 E3 C2

60x60 cm
24"x24"

Disponibile nello spessore 1 cm
Available in thickness 1 cm

 CATALOGO GENERALE GTOT
CATALOGO MATERIA

grigio



60x60 cm Rettificato
24"x24" Rectified

antracite



60x60 cm Rettificato
24"x24" Rectified

grafite



60x60 cm Rettificato
24"x24" Rectified

beige



60x60 cm Rettificato
24"x24" Rectified

SPECIAL SHAPES
FORME SPECIALI

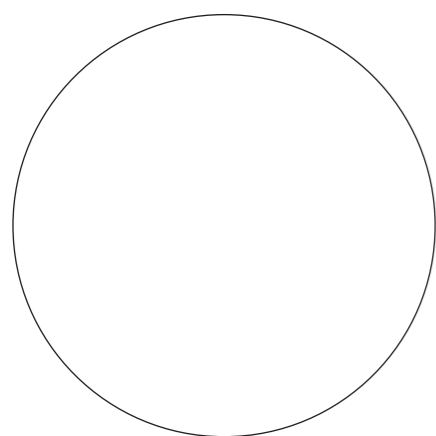

BUBBLE_60

56x56 cm
24"x24"



* LE FORME SPECIALI "ON DEMAND"
VENGONO REALIZZATI SOLO SU RICHIESTA
CON CONSEGNA 6 SETTIMANE.
SPECIAL SHAPES "ON DEMAND" ARE AVAILABLE ONLY
ON REQUEST AND HAVE A 6-WEEK LEAD-TIME.

OCEAN BLACK

+ plus
OUTDOOR PAVINGS



w i n d 60x60 cm Rettificato . 24"x24" Rectified



EFFETTO PIETRA

L' uomo e la pietra, un incontro che risale alla notte dei tempi. Il cuore pulsante dell'uomo e la durezza della pietra. Resistenza per la tua casa.

STONE EFFECT

Man and stone, a match that was born at the beginning of time. The beat of a man's heart and the strength of stone. Durability in your home.



Piscine
Pools



Giardini
Gardens

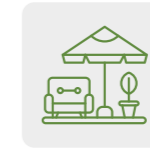

Terrazze
Terraces



Spazi pubblici
Public spaces

r o c k 60x60 cm Rettificato . 24"x24" Rectified



s a n d 60x60 cm Rettificato . 24"x24" Rectified



a b y s s 60x60 cm Rettificato . 24"x24" Rectified

OCEAN BLACK

EFFETTO PIETRA
STONE EFFECT

GRES PORCELLANATO IMPASTO COLORATO.
COLORED BODY PORCELAIN STONEWARE.

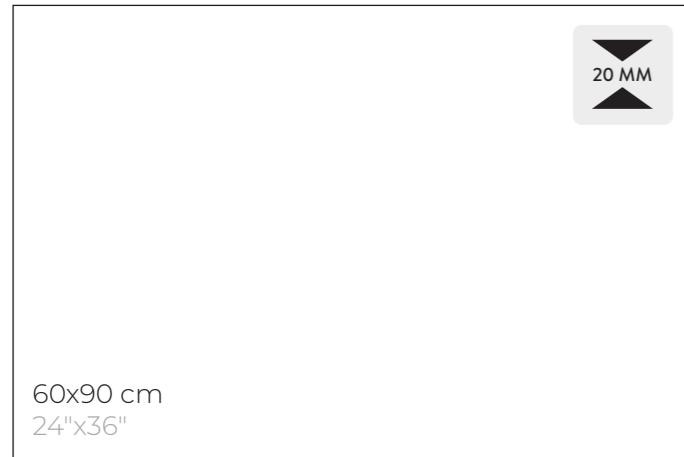

Disponibile nello spessore 1 cm
Available in thickness 1 cm



SPECIAL SHAPES FORME SPECIALI

* LE FORME SPECIALI "ON DEMAND"
VENGONO REALIZZATI SOLO SU RICHIESTA
CON CONSEGNA 6 SETTIMANE.
SPECIAL SHAPES "ON DEMAND" ARE AVAILABLE ONLY
ON REQUEST AND HAVE A 6-WEEK LEAD-TIME.

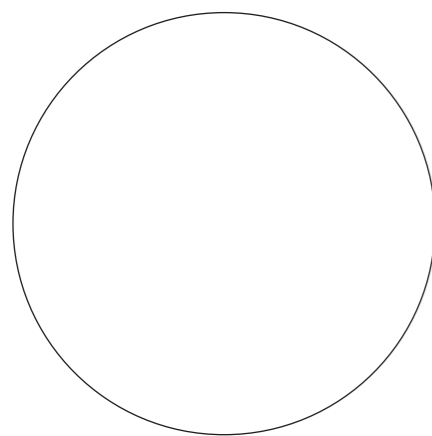

BUBBLE_60
56x56 cm
24"x24"

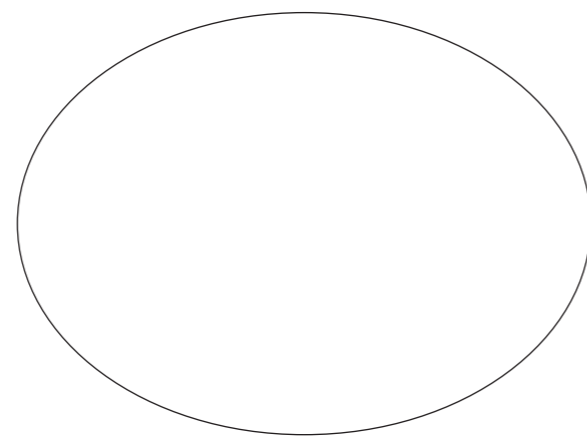

CLOUD_90
76x56 cm
32"x24"

abyss

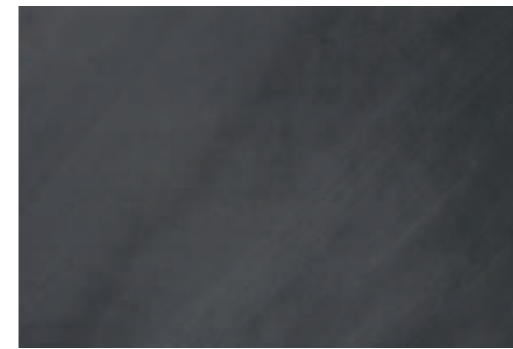

60x90 cm Rettificato
24"x36" Rectified

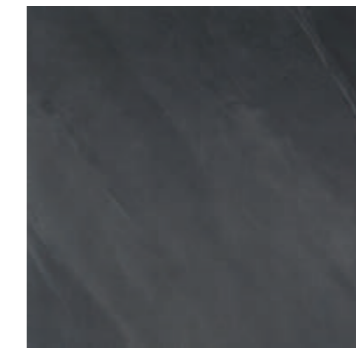

60x60 cm Rettificato
24"x24" Rectified

rock

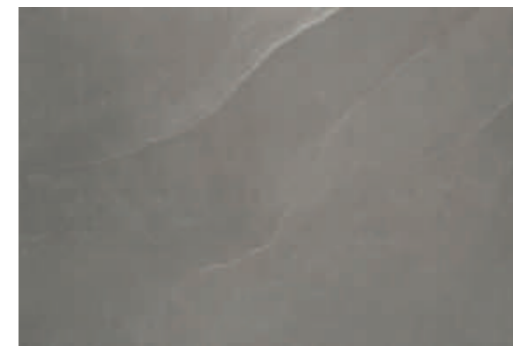

60x90 cm Rettificato
24"x36" Rectified

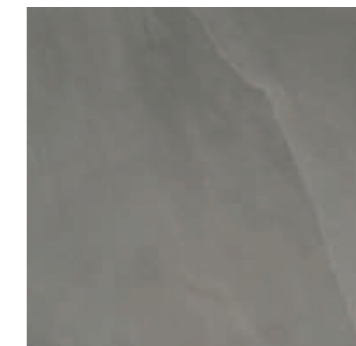

60x60 cm Rettificato
24"x24" Rectified

wind



60x90 cm Rettificato
24"x36" Rectified

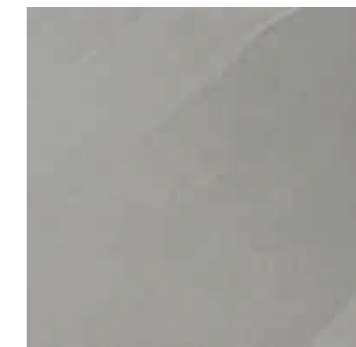

60x60 cm Rettificato
24"x24" Rectified

sand



60x90 cm Rettificato
24"x36" Rectified

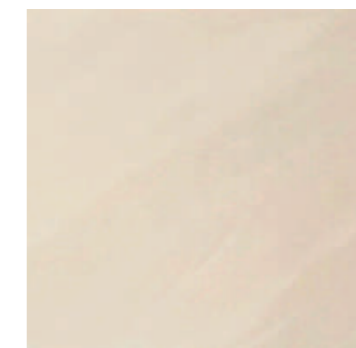

60x60 cm Rettificato
24"x24" Rectified

TREVI

+ plus
OUTDOOR PAVINGS



navona 80x80 cm Rettificato .32"x32" Rectified



GRADINO L 40x80 cm
L STEP 18"x32"

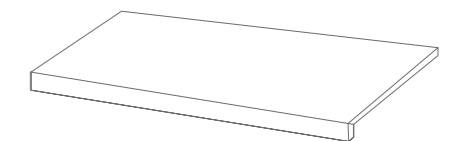

GRIGLIA 20x80 cm
GRID 8"x32"

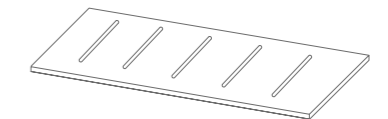

EFFETTO PIETRA

"La naturalezza del travertino rievocata dal colore CLASSICO della nostra collezione TREVI. Calde nuance adatte per pavimenti e rivestimenti per ambienti unici ed eleganti."

STONE EFFECT

The naturalness of travertine evoked by the CLASSIC color of our TREVI collection. Warm shades suitable for floors and walls for unique and elegant environments."



Piscine
Pools



Giardini
Gardens

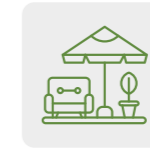

Terrazze
Terraces



Spazi pubblici
Public spaces

n o c e 80x80 cm Rettificato . 32"x32" Rectified



n o c e 80x80 cm Rettificato . 32"x32" Rectified



classico 80x80 cm Rettificato . 32"x32" Rectified

TREVI

EFFETTO PIETRA
STONE EFFECT

GRES PORCELLANATO IMPASTO COLORATO.
COLORED BODY PORCELAIN STONEWARE.

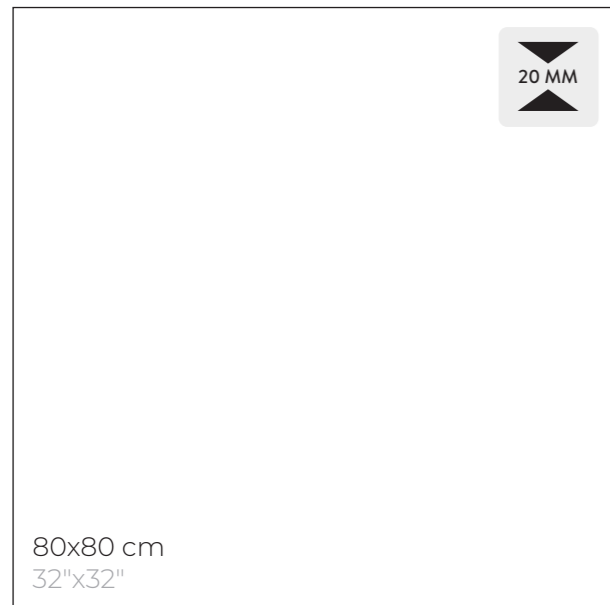

Disponibile nello spessore 1 cm
Available in thickness 1 cm



CATALOGO GENERALE GTOT
CATALOGO TREVI

SPECIAL SHAPES FORME SPECIALI

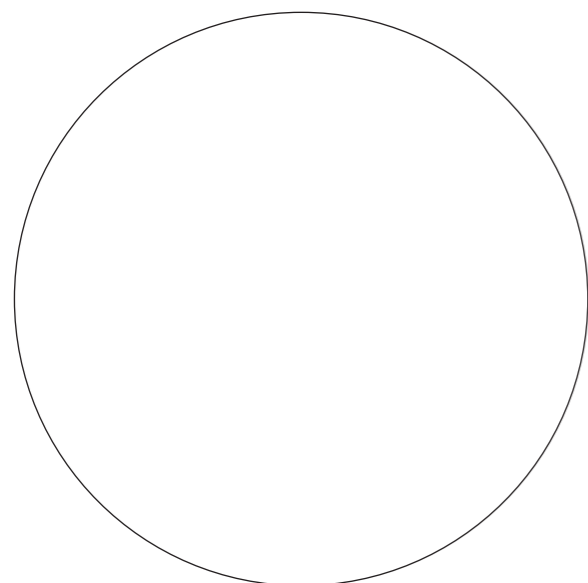

BUBBLE_80

76x76 cm
32"x32"

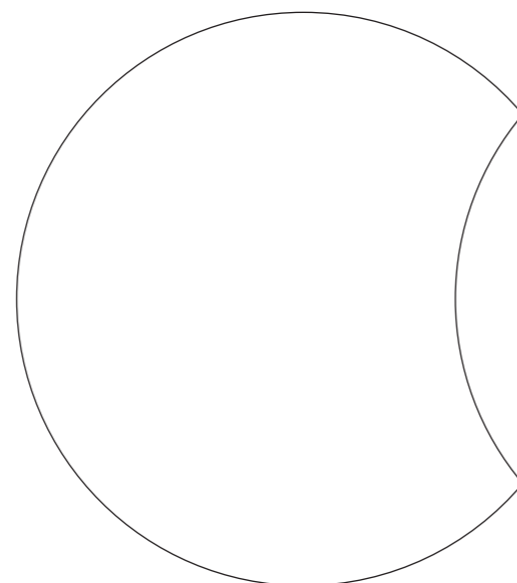

MOON_80

76x76 cm
32"x32"



* LE FORME SPECIALI "ON DEMAND"
VENGONO REALIZZATI SOLO SU RICHIESTA
CON CONSEGNA 6 SETTIMANE.
SPECIAL SHAPES "ON DEMAND" ARE AVAILABLE ONLY
ON REQUEST AND HAVE A 6-WEEK LEAD-TIME.

navona



80x80 cm Rettificato
32"x32" Rectified

classico



80x80 cm Rettificato
32"x32" Rectified

noce



80x80 cm Rettificato
32"x32" Rectified

U N I K A

+ plus
OUTDOOR PAVINGS



smoke 80x80 cm Rettificato . 32"x32" Rectified



EFFETTO CEMENTO

"Una serie ispirata all'estetica e matericità del cemento per esigenze commerciali e residenziali."

CONCRETE EFFECT

"A series inspired by the style and material quality of cement, for both commercial and residential projects."



Piscine
Pools



Giardini
Gardens

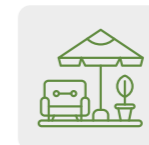

Terrazze
Terraces



Spazi pubblici
Public spaces

carbon 80x80 cm Rettificato . 32"x32" Rectified



smoke 60x60 cm Rettificato . 24"x24" Rectified

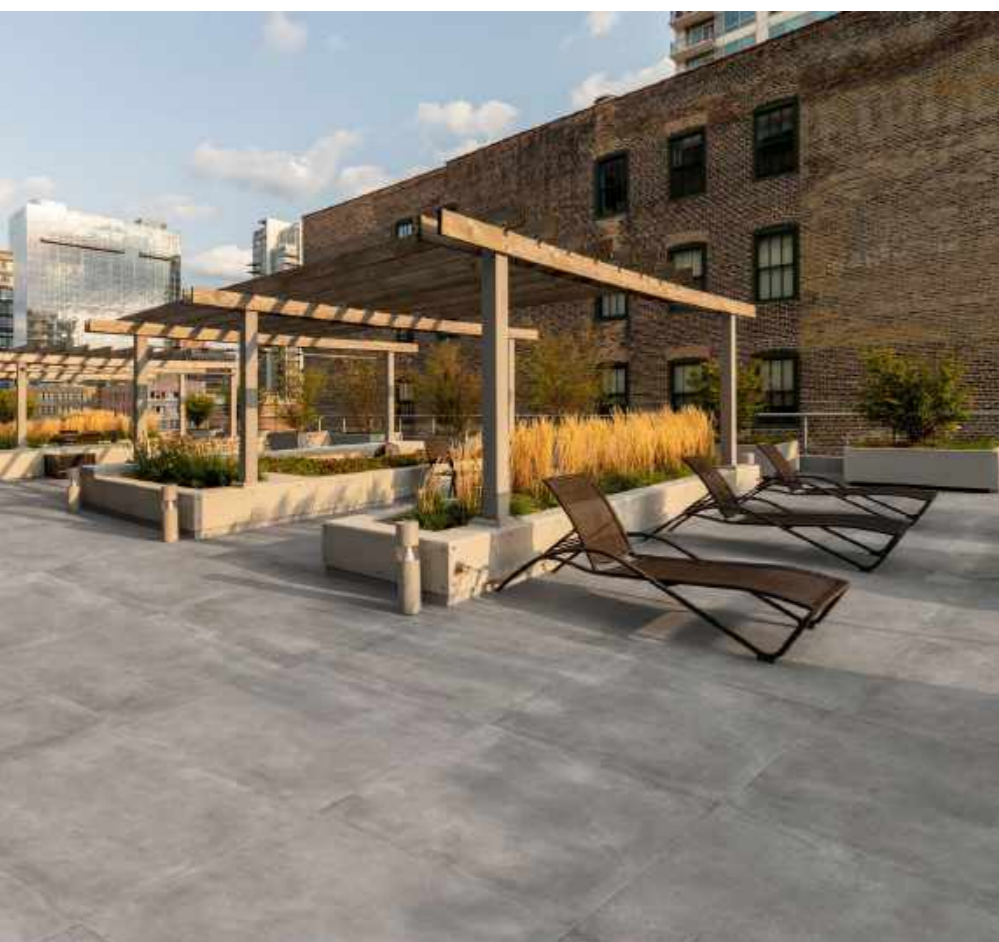

sand 80x80 cm Rettificato . 32"x32" Rectified

UNIKA

EFFETTO CEMENTO
CONCRETE EFFECT

GRES PORCELLANATO IMPASTO COLORATO.
COLORED BODY PORCELAIN STONEWARE.

QB UPEC.F+ 20 MM

U4 P3 E3 C2

80x80 cm
32"x32"

30 MM

Disponibile nello spessore 1 cm
Available in thickness 1 cm

CATALOGO GENERALE GTOT
CATALOGO UNIKA

QB UPEC.F+ 20 MM

U4 P3 E3 C2

60x60 cm
24"x24"

30 MM

SPECIAL SHAPES FORME SPECIALI

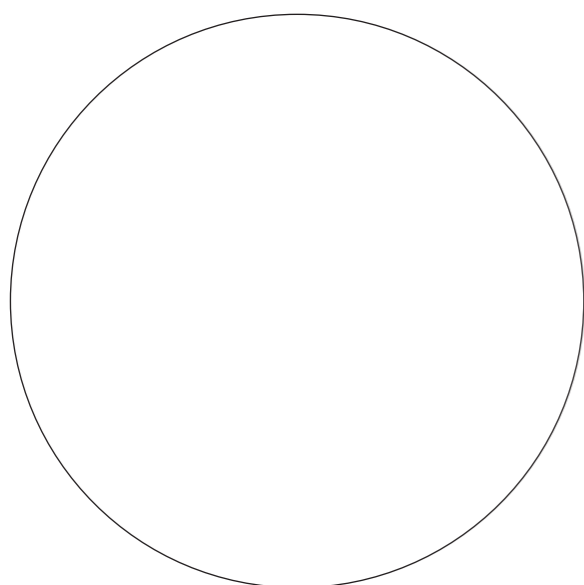

BUBBLE_80
76x76 cm
32"x32"



BUBBLE_60
56x56 cm
24"x24"

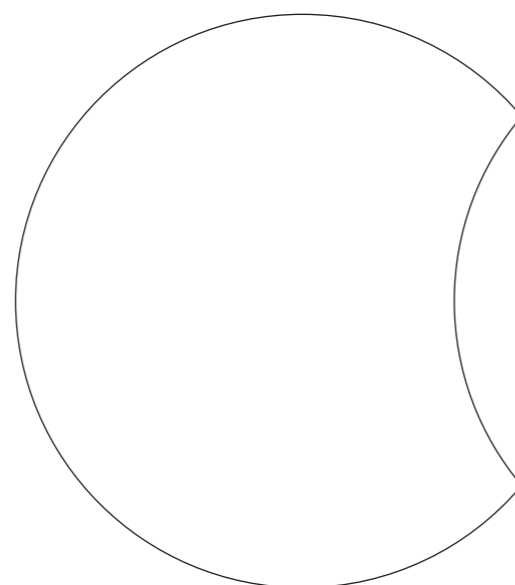

MOON_80
76x76 cm
32"x32"



* LE FORME SPECIALI "ON DEMAND"
VENGONO REALIZZATI SOLO SU RICHIESTA
CON CONSEGNA 6 SETTIMANE.
SPECIAL SHAPES "ON DEMAND" ARE AVAILABLE ONLY
ON REQUEST AND HAVE A 6-WEEK LEAD-TIME.

carbon



80x80 cm Rettificato
32"x32" Rectified



60x60 cm Rettificato
24"x24" Rectified

smoke



80x80 cm Rettificato
32"x32" Rectified



60x60 cm Rettificato
24"x24" Rectified

sand



80x80 cm Rettificato
32"x32" Rectified



60x60 cm Rettificato
24"x24" Rectified

X O

—

+ plus
OUTDOOR PAVINGS



t o b a c c o 80x80 cm Rettificato . 32"x32" Rectified



EFFETTO PIETRA

Un design minimal, ma versatile, una rivisitazione cromatica di tendenza dello stile industrial per progetti moderni e sofisticati. Nuovi colori, decori e formati per un classico evergreen.

"Your perfect stylish tile "

STONE EFFECT

"A minimal but all-around design, a new chromatic interpretation of the industrial style trend, for modern and sophisticated projects. New colors, decors and sizes for a classic evergreen.

"Your perfect stylish tile"



Piscine
Pools



Giardini
Gardens

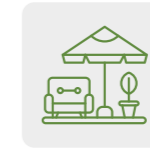

Terrazze
Terraces



Spazi pubblici
Public spaces

smoke 80x80 cm Rettificato . 32"x32" Rectified



midnight 80x80 cm Rettificato . 32"x32" Rectified



poudre 80x80 cm Rettificato . 32"x32" Rectified



Disponibile nello spessore 1 cm
Available in thickness 1 cm

CATALOGO GENERALE GTOT
CATALOGO XO

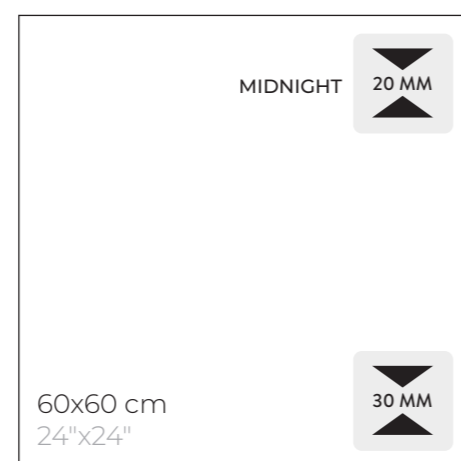

SPECIAL SHAPES
FORME SPECIALI

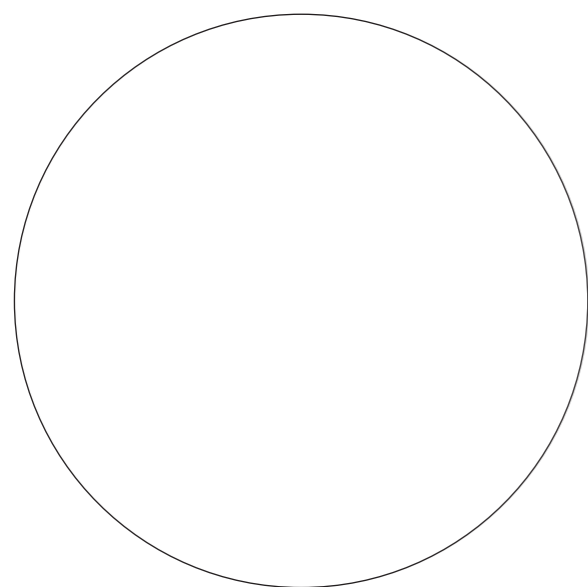

BUBBLE_80

76x76 cm
32"x32"

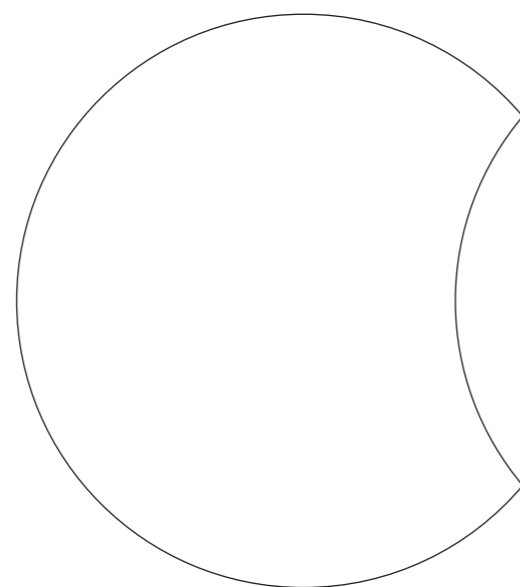

MOON_80

76x76 cm
32"x32"



BUBBLE_60

56x56 cm
24"x24"



SOLO COLORE MIDNIGHT
only MIDNIGHT color

* LE FORME SPECIALI "ON DEMAND"
VENGONO REALIZZATI SOLO SU RICHIESTA
CON CONSEGNA 6 SETTIMANE.
SPECIAL SHAPES "ON DEMAND" ARE AVAILABLE ONLY
ON REQUEST AND HAVE A 6-WEEK LEAD-TIME.



smoke



80x80 cm Rettificato
32"x32" Rectified



60x60 cm Rettificato
24"x24" Rectified solo 30mm
only 30mm

poudre



80x80 cm Rettificato
32"x32" Rectified



60x60 cm Rettificato
24"x24" Rectified solo 30mm
only 30mm

tobacco



80x80 cm Rettificato
32"x32" Rectified



60x60 cm Rettificato
24"x24" Rectified solo 30mm
only 30mm

cement



80x80 cm Rettificato
32"x32" Rectified



60x60 cm Rettificato solo 30mm
24"x24" Rectified only 30mm

midnight



80x80 cm Rettificato solo 20mm
32"x32" Rectified only 20mm



60x60 cm Rettificato solo 20mm
24"x24" Rectified only 20mm



cement 80x80 cm Rettificato . 32"x32" Rectified

—

T R I M
P I E C E S

72

Piscine & solarium
swimming pools & solarium

76

Scale & gradini
steps & stairways

78

Arredi & accessori
furniture & fittings

82

Copertine
copings

Una gamma di gres 20mm / 30mm adatto a tutti i tipi di pavimentazioni esterne, anche sopraelevate.
Un nuovo modo di pavimentare terrazze, giardini, solai, piscine, coniugando design, con facilità di posa e sostenibilità ambientale.

Plus Trim è la chiave per creare nuovi elementi architettonici in completa sintonia con gli spazi circostanti.

PLUS
TRIMS

A range of stoneware suitable for all types of outdoor flooring, also raised, a new way of paving terraces, gardens, floors, pools, combining design, with an easy installation and environmental sustainability.



A key to create new architectural elements in complete harmony with the surrounding spaces.



PISCINE

SU RICHIESTA* ON DEMAND*

SWIMMING POOLS & SOLARIUM



GRADINO MONOGRAFICO
MONOGRAPHIC STEP

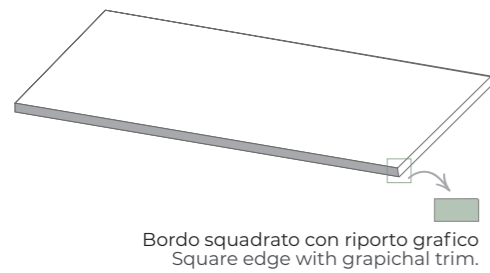

ANGOLO MONOGRAFICO
MONOGRAPHIC ANGLE

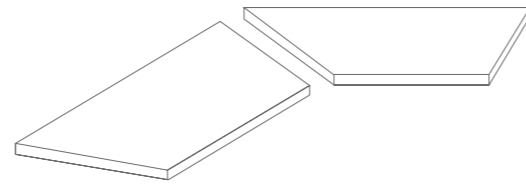

GRADINO COSTA RETTA
RIGHT EDGE STEP

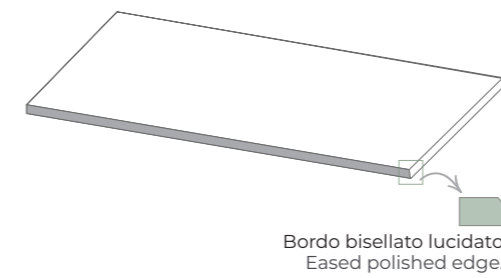

BORDO CURVILINEO TORO
O COSTA RETTA
CURVED TORUS EDGE
OR STRAIGHT EDGE

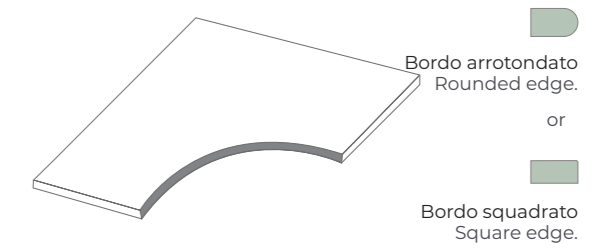

TORO GRADINO
TORUS STEP

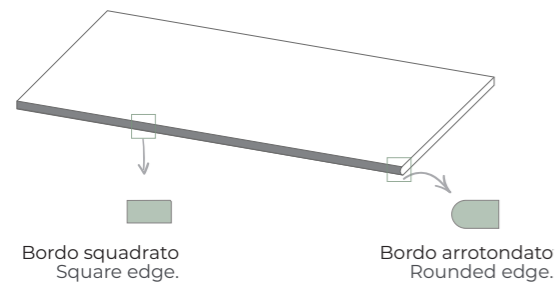

TORO ANGOLO DX/SX
TORUS ANGLE L/R

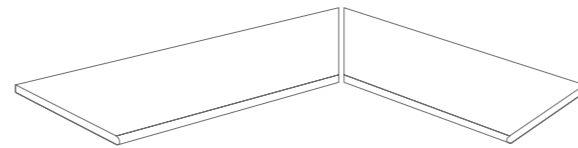

BORDO ANTISCIVOLO
ANTI-SKID EDGE

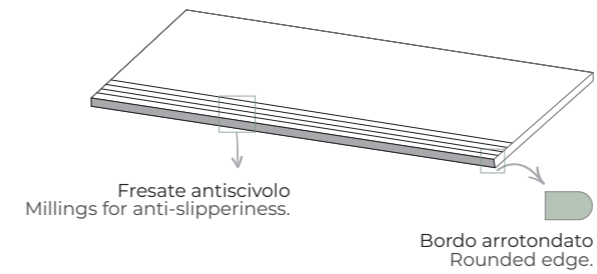

BORDO ANTISCIVOLO
ANGOLO DX/SX
ANTI-SKID EDGE ANGLE L/R

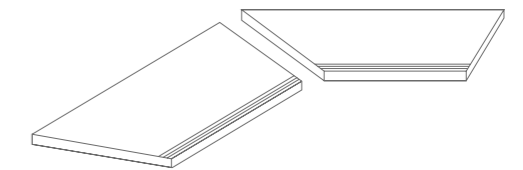

GRADINO L
L STEP

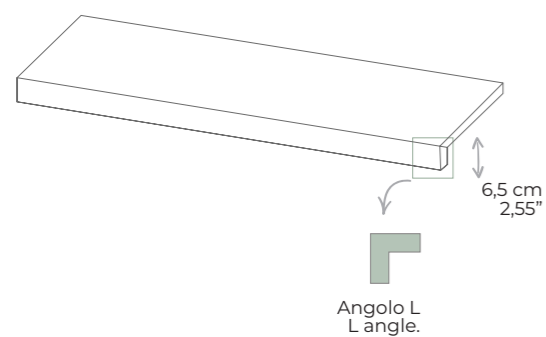

ANGOLO L
ANGLE L

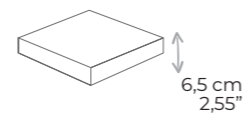

ANGOLO L DX/SX
ANGLE L L/R

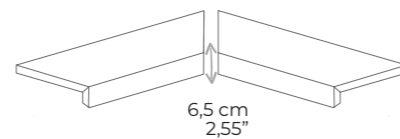

GRIGLIA
GRID

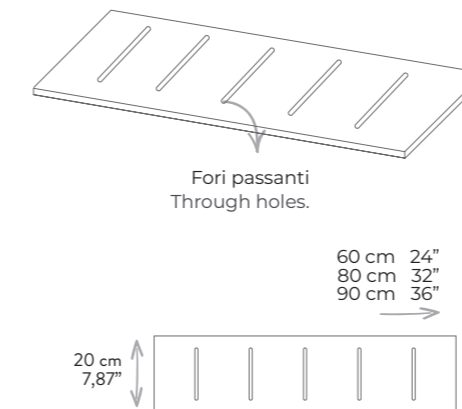

ANGOLO GRIGLIA DX/SX
ANGLE GRID L/R

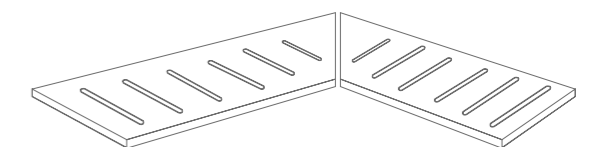

* I PEZZI SPECIALI "ON DEMAND" VENGONO REALIZZATI SOLO SU RICHIESTA CON CONSEGNA 6 SETTIMANE.
SPECIAL PIECES "ON DEMAND" ARE AVAILABLE ONLY ON REQUEST AND HAVE A 6-WEEK LEAD-TIME.

* I PEZZI SPECIALI "ON DEMAND" VENGONO REALIZZATI SOLO SU RICHIESTA CON CONSEGNA 6 SETTIMANE.
SPECIAL PIECES "ON DEMAND" ARE AVAILABLE ONLY ON REQUEST AND HAVE A 6-WEEK LEAD-TIME.

PISCINE







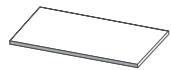
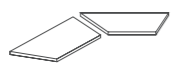

SU RICHIESTA* ON DEMAND*

SWIMMING POOLS & SOLARIUM

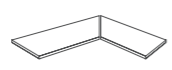

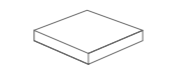
FORMATI DISPONIBILI
AVAILABLE SIZES

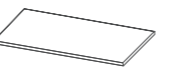
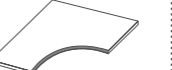
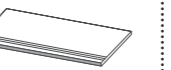
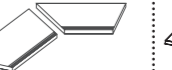
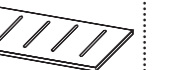

													
	MONOGRAPHIC STEP	MONOGRAPHIC ANGLE	TAURUS STEP	TAURUS ANGLE	L STEP	ANGLE L	ANGLE L L/R	RIGHT EDGE STEP	CURVED TORUS EDGE OR STRAIGHT EDGE	ANTI-SKID EDGE	ANTI-SKID EDGE ANGLE L/R	GRID	ANGLE GRID L/R
ASGARD	cm 30x60 12"x24"	cm 60x60 24"x24"	cm 30x60 12"x24"	cm 60x60 24"x24"	cm 30x60 12"x24"	cm 60x60 24"x24"	cm 60x60 24"x24"	cm 30x60 12"x24"	cm 60x60 24"x24"	cm 30x60 12"x24"	cm 60x60 24"x24"	cm 20x60 8"x24"	cm 60x60 24"x24"
BET	cm 30x60 12"x24"	cm 60x60 24"x24"	cm 30x60 12"x24"	cm 60x60 24"x24"	cm 30x60 12"x24"	cm 60x60 24"x24"	cm 60x60 24"x24"	cm 30x60 12"x24"	cm 60x60 24"x24"	cm 30x60 12"x24"	cm 60x60 24"x24"	cm 20x60 8"x24"	cm 60x60 24"x24"
BORDEAUX	cm 30x90 12"x36"	cm 90x90 36"x36"	cm 30x90 12"x36"	cm 90x90 36"x36"	cm 30x90 12"x36"	cm 90x90 36"x36"	cm 90x90 36"x36"	cm 30x90 12"x36"	cm 90x90 36"x36"	cm 30x90 12"x36"	cm 90x90 36"x36"	cm 20x90 8"x236"	cm 90x90 36"x36"
BLUE LABEL	cm 40x80 16"x32"	cm 80x80 32"x32"	cm 40x80 16"x32"	cm 80x80 32"x32"	cm 40x80 16"x32"	cm 80x80 32"x32"	cm 80x80 32"x32"	cm 40x80 16"x32"	cm 80x80 32"x32"	cm 40x80 16"x32"	cm 80x80 32"x32"	cm 20x80 8"x32"	cm 80x80 32"x32"
HEMISPHERE	cm 30x60 12"x24"	cm 60x60 24"x24"	cm 30x60 12"x24"	cm 60x60 24"x24"	cm 30x60 12"x24"	cm 60x60 24"x24"	cm 60x60 24"x24"	cm 30x60 12"x24"	cm 60x60 24"x24"	cm 30x60 12"x24"	cm 60x60 24"x24"	cm 20x60 8"x24"	cm 60x60 24"x24"
MATERIA	cm 30x60 12"x24"	cm 60x60 24"x24"	cm 30x60 12"x24"	cm 60x60 24"x24"	cm 30x60 12"x24"	cm 60x60 24"x24"	cm 60x60 24"x24"	cm 30x60 12"x24"	cm 60x60 24"x24"	cm 30x60 12"x24"	cm 60x60 24"x24"	cm 20x60 8"x24"	cm 60x60 24"x24"
OCEAN BLACK	cm 30x60 12"x24"	cm 60x60 24"x24"	cm 30x60 12"x24"	cm 60x60 24"x24"	cm 30x60 12"x24"	cm 60x60 24"x24"	cm 60x60 24"x24"	cm 30x60 12"x24"	cm 60x60 24"x24"	cm 30x60 12"x24"	cm 60x60 24"x24"	cm 20x60 8"x24"	cm 60x60 24"x24"
TREVI	cm 30x90 12"x36"	cm 90x90 36"x36"	cm 30x90 12"x36"	cm 90x90 36"x36"	cm 30x90 12"x36"	cm 90x90 36"x36"	cm 90x90 36"x36"	cm 30x90 12"x36"	cm 90x90 36"x36"	cm 30x90 12"x36"	cm 90x90 36"x36"	cm 20x90 8"x236"	cm 90x90 36"x36"
UNIKA	cm 40x80 16"x32"	cm 80x80 32"x32"	cm 40x80 16"x32"	cm 80x80 32"x32"	cm 40x80 16"x32"	cm 80x80 32"x32"	cm 80x80 32"x32"	cm 40x80 16"x32"	cm 80x80 32"x32"	cm 40x80 16"x32"	cm 80x80 32"x32"	cm 20x80 8"x32"	cm 80x80 32"x32"
XO	cm 40x80 16"x32"	cm 80x80 32"x32"	cm 40x80 16"x32"	cm 80x80 32"x32"	cm 40x80 16"x32"	cm 80x80 32"x32"	cm 80x80 32"x32"	cm 40x80 16"x32"	cm 80x80 32"x32"	cm 40x80 16"x32"	cm 80x80 32"x32"	cm 20x80 8"x32"	cm 80x80 32"x32"



GRADINO MONOGRAFICO MONOGRAPHIC STEP

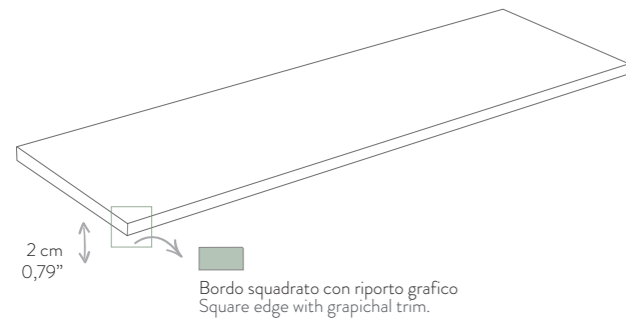

TORO GRADINO TORUS STEP

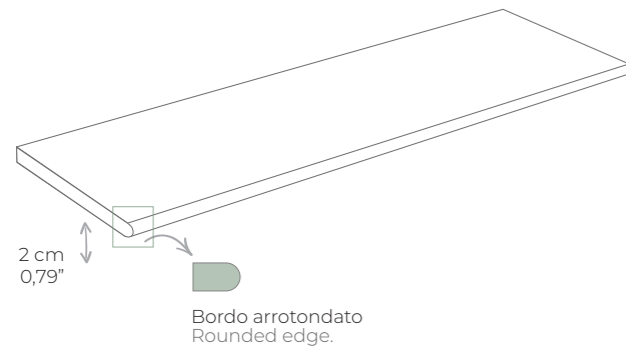

GRADINO L L STEP

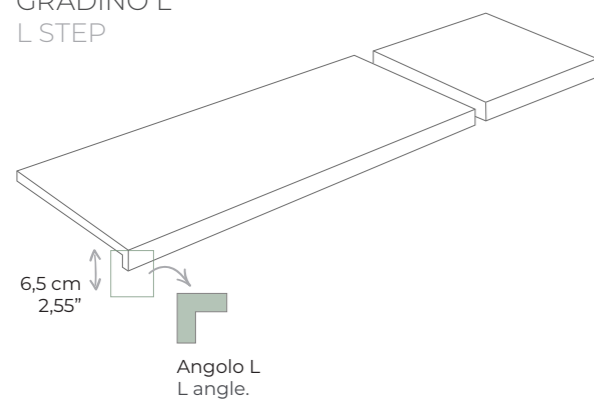

FORMATI DISPONIBILI
AVAILABLE SIZES



GRADINO MONOGRAFICO
MONOGRAPHIC STEP

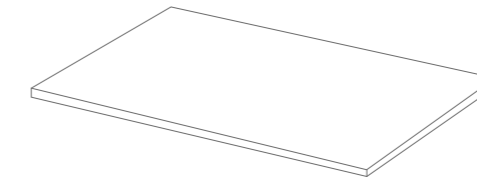

80x40x2 cm
32"x16"x0,79"

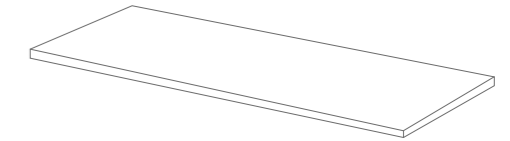

90x30x2 cm
36"x12"x0,79"



TORO GRADINO
TORUS STEP

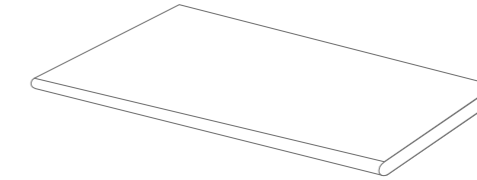

80x40x2 cm
32"x16"x0,79"

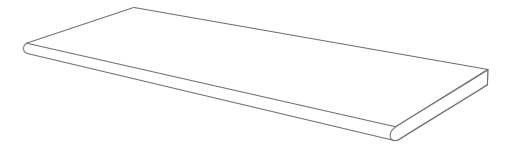

90x30x2 cm
36"x12"x0,79"



L GRADINO
L STEP

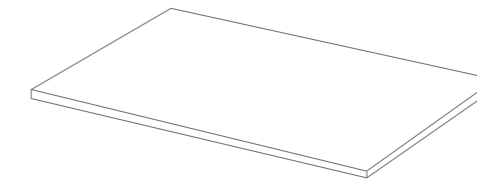

80x40x2 cm
32"x16"x0,79"

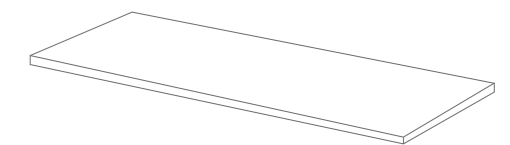

90x30x2 cm
36"x12"x0,79"

* I PEZZI SPECIALI "ON DEMAND" VENGONO REALIZZATI SOLO SU RICHIESTA CON CONSEGNA 6 SETTIMANE.
SPECIAL PIECES "ON DEMAND" ARE AVAILABLE ONLY ON REQUEST AND HAVE A 6-WEEK LEAD-TIME.

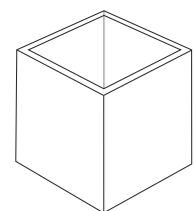

FIORIERA CUBO
CUBE PLANTER

cm 60x60x60

DISPONIBILE NELLE COLLEZIONI
Available on
BET . OCEAN BLACK . MATERIA .
UNIKA . HEMISPHERE . ASGARD

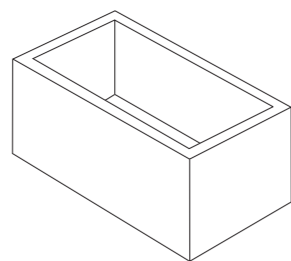

FIORIERA BASSA
LOW PLANTER

cm 90x60x45

DISPONIBILE NELLE COLLEZIONI
Available on
BET . BORDEAUX . OCEAN BLACK

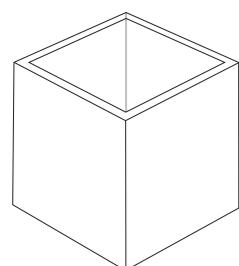

FIORIERA CUBO
CUBE PLANTER

cm 80x80x80

DISPONIBILE NELLE COLLEZIONI
Available on
BLUE LABEL . UNIKA . XO
HEMISPHERE . TREVÌ

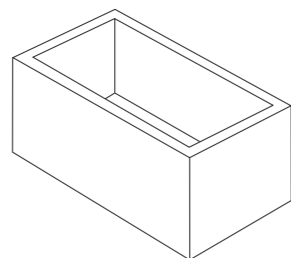

FIORIERA BASSA
LOW PLANTER

cm 80x40x40

DISPONIBILE NELLE COLLEZIONI
Available on
BLUE LABEL . UNIKA . XO
HEMISPHERE . TREVÌ

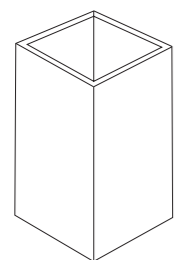

FIORIERA CUBO ALTA
HIGH CUBE PLANTER

cm 40x40x80

DISPONIBILE NELLE COLLEZIONI
Available on
BLUE LABEL . UNIKA . XO
HEMISPHERE . TREVÌ

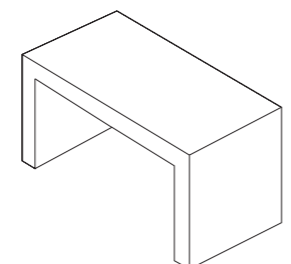

PANCHINA
BENCH

cm 90x60x45

DISPONIBILE NELLE COLLEZIONI
Available on
BET . BORDEAUX . OCEAN BLACK

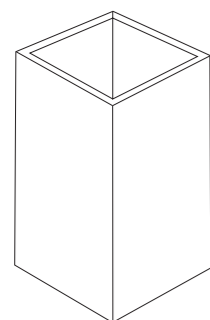

FIORIERA CUBO ALTA
HIGH CUBE PLANTER

cm 60x60x90

DISPONIBILE NELLE COLLEZIONI
Available on
BET . BORDEAUX . OCEAN BLACK

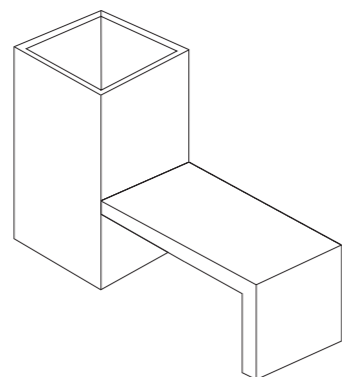

STATION COMBO

FIORIERA CUBO ALTA 40x40x80
+ PANCHINA 80x40x45

DISPONIBILE NELLE COLLEZIONI
Available on
BLUE LABEL . UNIKA . XO
HEMISPHERE . TREVÌ

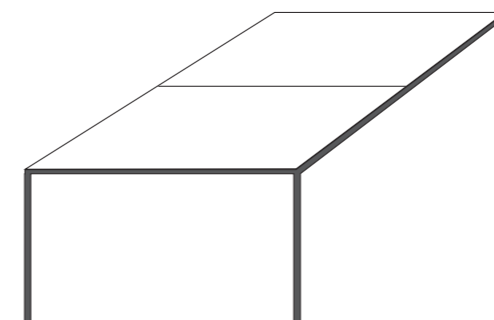

TAVOLINO IBRIDO FERRO CON PIANO IN GRES SPESSORE 20 MM

HYBRID IRON TABLE WITH GRES TOP THICKNESS 20 MM

cm 160x80x45

cm 160x80x75

DISPONIBILE NELLE COLLEZIONI
Available on
UNIKA . XO . HEMISPHERE . BLUE LABEL



* GLI ARREDI "ON DEMAND" VENGONO REALIZZATI SOLO SU RICHIESTA CON CONSEGNA 6 SETTIMANE.
FURNISHING "ON DEMAND" ARE AVAILABLE ONLY ON REQUEST AND HAVE A 6-WEEK LEAD-TIME.

* GLI ARREDI "ON DEMAND" VENGONO REALIZZATI SOLO SU RICHIESTA CON CONSEGNA 6 SETTIMANE.
FURNISHING "ON DEMAND" ARE AVAILABLE ONLY ON REQUEST AND HAVE A 6-WEEK LEAD-TIME.

ARREDI

SU RICHIESTA* ON DEMAND*

FURNITURES & FITTINGS



FORMATI DISPONIBILI
AVAILABLE SIZES

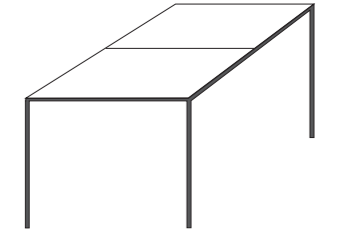
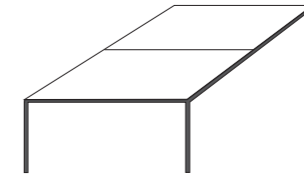
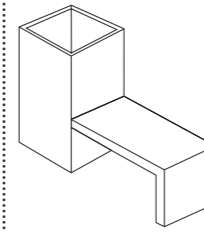
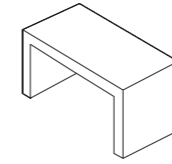
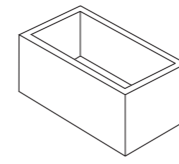
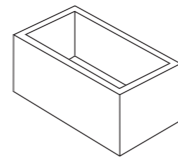
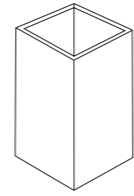
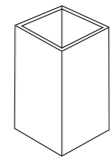
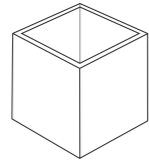
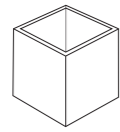

FIORIERA CUBO
cm 60x60x60

FIORIERA CUBO
cm 80x80x80

FIORIERA CUBO ALTA
cm 40x40x80

FIORIERA CUBO ALTA
cm 60x60x90

FIORIERA BASSA
cm 90x60x45

FIORIERA BASSA
cm 80x40x40

PANCHINA
cm 90x60x45

STATION COMBO

TAVOLINO IBRIDO FERRO CON PIANO IN GRES
SPESSORE 20 MM
cm 160x80x45

TAVOLINO IBRIDO FERRO CON PIANO IN GRES
SPESSORE 20 MM
cm 160x80x75

CUBE PLANTER

CUBE PLANTER

HIGH CUBE PLANTER

HIGH CUBE PLANTER

LOW PLANTER

LOW PLANTER

BENCH

STATION COMBO

HYBRID IRON TABLE WITH GRES TOP
THICKNESS 20 MM

HYBRID IRON TABLE WITH GRES TOP
THICKNESS 20 MM

	FIORIERA CUBO cm 60x60x60	FIORIERA CUBO cm 80x80x80	FIORIERA CUBO ALTA cm 40x40x80	FIORIERA CUBO ALTA cm 60x60x90	FIORIERA BASSA cm 90x60x45	FIORIERA BASSA cm 80x40x40	PANCHINA cm 90x60x45	STATION COMBO	TAVOLINO IBRIDO FERRO CON PIANO IN GRES SPESSORE 20 MM cm 160x80x45	TAVOLINO IBRIDO FERRO CON PIANO IN GRES SPESSORE 20 MM cm 160x80x75
ASGARD	•									
BET	•			•	•		•			
BLUE LABEL		•	•			•			•	•
BORDEAUX				•	•		•			
HEMISPHERE	•	•	•			•		•	•	•
MATERIA	•									
OCEAN BLACK	•			•	•		•			
TREVI		•	•			•		•	•	•
UNIKA	•	•	•			•		•	•	•
XO		•	•			•		•	•	•

COPERTINE

SU RICHIESTA* ON DEMAND*



COPINGS

COPERTINA cm 30x60
COPINGS 12"x24"

COPERTINA cm 40x80
COPINGS 16"x32"

CAPITELLO cm 40x80
SHRINE 16"x16"

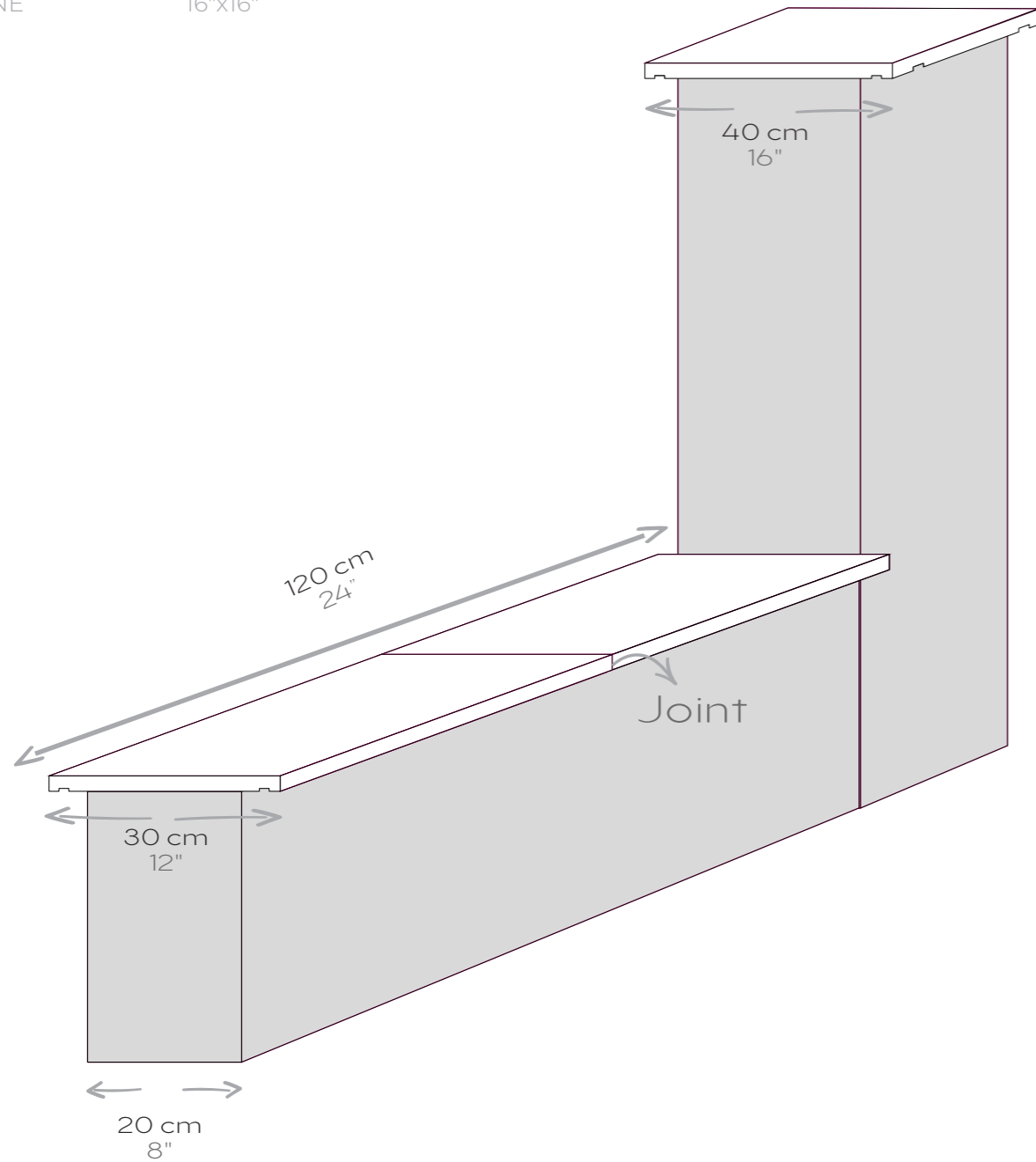

* I PEZZI SPECIALI "ON DEMAND" VENGONO REALIZZATI SOLO SU RICHIESTA CON CONSEGNA 6 SETTIMANE.
SPECIAL PIECES "ON DEMAND" ARE AVAILABLE ONLY ON REQUEST AND HAVE A 6-WEEK LEAD-TIME.

FORMATI DISPONIBILI
AVAILABLE SIZES

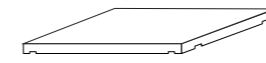
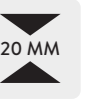

CAPITELLO
cm 40x40

SHRINE

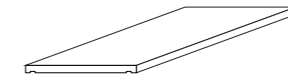

COPERTINA
cm 30x60

COPINGS

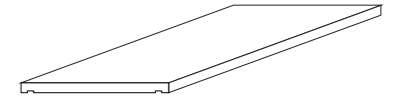

COPERTINA
cm 40x80

COPINGS

	CAPITELLO cm 40x40 SHRINE	COPERTINA cm 30x60 COPINGS	COPERTINA cm 40x80 COPINGS
ASGARD	•	•	
BET	•	•	
BLUE LABEL	•		•
BORDEAUX	•	•	
HEMISPHERE	•	•	•
MATERIA	•	•	
OCEAN BLACK	•	•	
TREVI	•		•
UNIKA	•	•	•
XO	•		•

GRIGLIE PER ALBERI

TREE GRID

SU RICHIESTA* ON DEMAND*



FORMATI DISPONIBILI
AVAILABLE SIZES

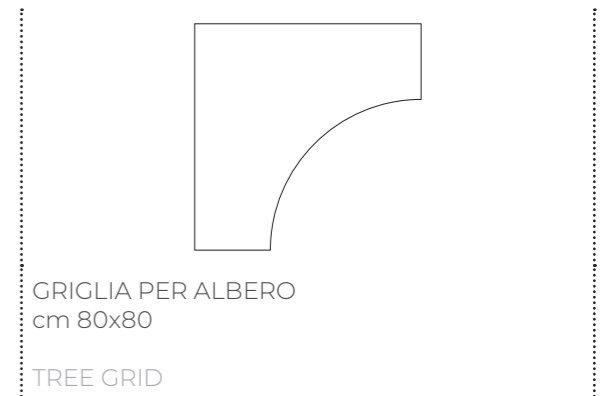
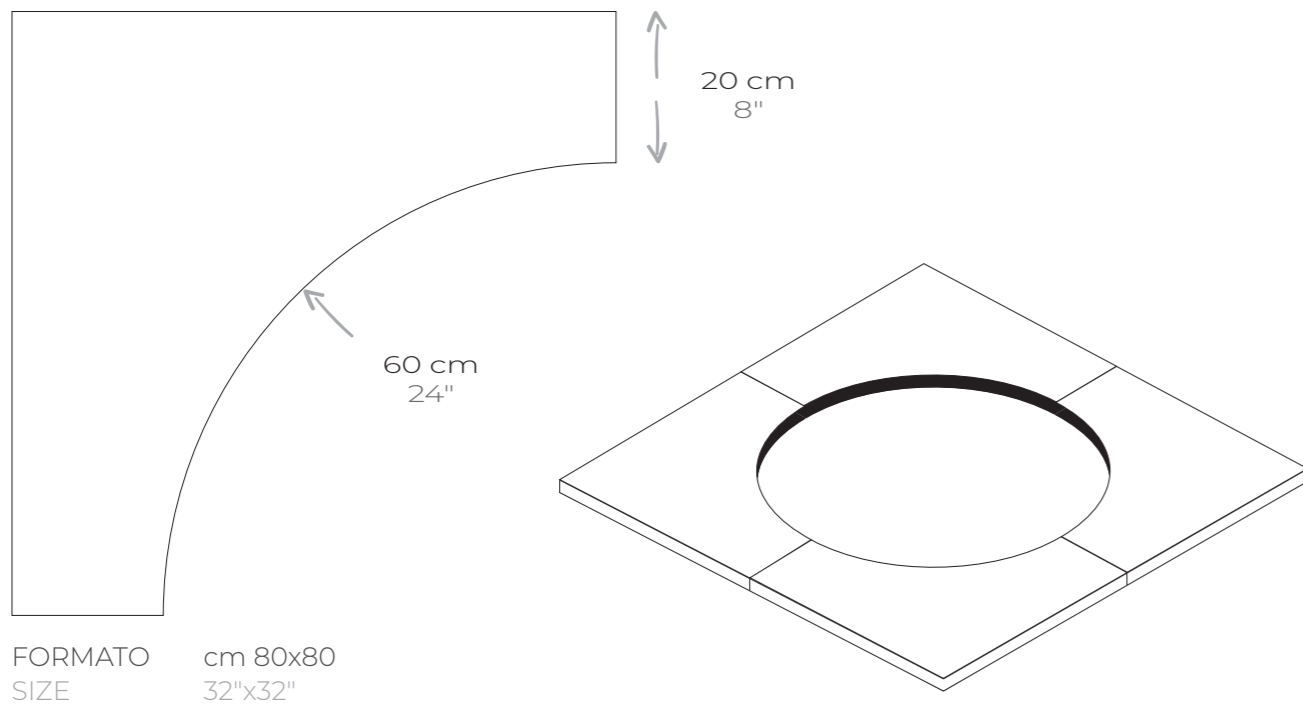
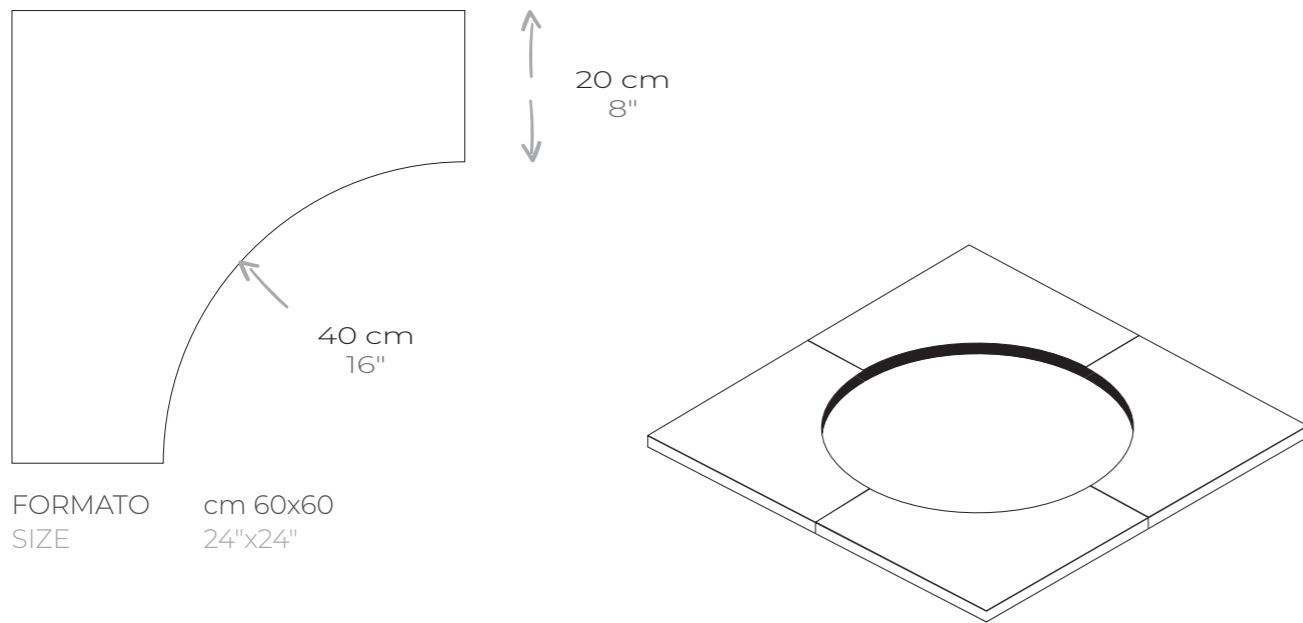

ASGARD	•	
BET	•	
BLUE LABEL		•
BORDEAUX		
HEMISPHERE	•	•
MATERIA	•	
OCEAN BLACK	•	
TREVI		•
UNIKA	•	•
XO	•	•

* I PEZZI SPECIALI "ON DEMAND" VENGONO REALIZZATI SOLO SU RICHIESTA CON CONSEGNA 6 SETTIMANE.
SPECIAL PIECES "ON DEMAND" ARE AVAILABLE ONLY ON REQUEST AND HAVE A 6-WEEK LEAD-TIME.

SISTEMI DI POSA

installation systems

+ plus
OUTDOOR PAVINGS



POSA A SECCO SU SABBIA

1. Predisporre il letto di sabbia di almeno 5-10 cm. Livellare il letto di posa con un apposito strumento.
2. Posizionare le lastre secondo lo schema di posa scelto e battere con accortezza le superfici utilizzando un martello in gomma.
3. Si suggerisce di posare le lastre con una fuga adeguata allo schema di posa prescelto.

INSTALLATION ON SAND

1. Prepare and compact the sand ground for 5-10cm
2. Install the pavers following the installation scheme and use a rubber hammer to correct the small gaps.
3. It is suggested to install the pavers with a joint adequate to the chosen laying pattern.



POSA A SECCO SU ERBA

1. Rimuovere il più possibile il manto erboso dalla zona in cui si appoggeranno le lastre e bagnare il terreno
2. Posizionare le lastre secondo lo schema di posa scelto e battere con accortezza le superfici utilizzando un martello in gomma bianca / PVC per farle aderire correttamente al supporto.
3. Si suggerisce di posare le lastre con almeno 2 cm di fuga le une dalle altre.

INSTALLATION ON GRASS

1. Remove the grass in the area where the pavers will be installed and wet the ground.
2. Install the pavers following the installation scheme and use a rubber hammer to correct the small differences in height and to make pavers stick completely to the layer.
3. It is suggested to install the pavers with a minimum 2cm joint.



POSA A SECCO SU GHIAIA

1. Scavare il sottofondo per circa 15 cm.
2. Predisporre uno strato di 10 cm di ghiaia mista a pietrisco per permettere un buon deflusso delle acque piovane.
- Al fine di evitare possibili cedimenti della pavimentazione, compattare e livellare il fondo con una pendenza minima del 2%.
3. Creare un letto di posa composto da ghiaia a granulometria 4-8 mm per uno spessore di almeno 10 cm e livellare il letto di posa.
4. Posizionare le lastre secondo lo schema di posa scelto e battere con accortezza le superfici utilizzando un martello in gomma bianca.
5. Si suggerisce di posare le lastre con almeno 3 mm di fuga le une dalle altre, utilizzando opportuni distanziatori tra le piastrelle. Le fughe potranno essere lasciate vuote, riempite con sabbia lavata non argillosa oppure con fugante in sabbia polimerica drenante.

INSTALLATION ON GRAVEL

1. Dig the soil for 15 cm
2. Prepare a 10cm layer of gravel mixed crushed stone that allows a proper drainage of the water.
- In order to avoid any floor cave in, it is suggested to compact and level the ground with a minimum 2% slope.
3. Prepare a layer of 4-8mm grain gravel for a thickness of 10cm and level it.
4. Install the pavers following the installation scheme and use a rubber hammer to adjust the different levels.
5. It is suggested to install the pavers with a minimum 3mm joint, using appropriate spacers. The joints can be left empty, filled with thin sand or filled with polymeric sand.

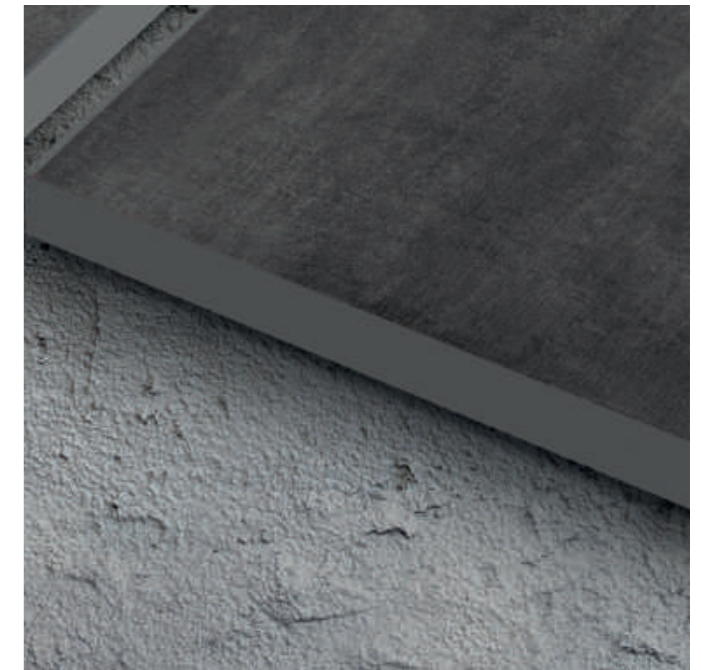

POSA TRADIZIONALE

1. Predisporre uno strato di 10 cm di ghiaia mista a pietrisco e realizzare un getto di calcestruzzo.
2. Stendere un massetto rinforzato di almeno 5 cm con eventuale rete elettrosaldata inserita a 2/3 dello spessore.
3. Incollare le lastre con il metodo della doppia spalmatura con adesivi cementizi migliorati altamente deformabili.
4. Si suggerisce di posare le lastre con almeno 5 mm di fuga le une dalle altre, utilizzando malte cementizie per fughe migliorate.
5. Ogni 9-16 mq, in funzione delle dimensioni e della forma geometrica del pavimento, sarà necessario inserire idonei giunti di dilatazione di ampiezza non inferiore a 5mm.

INSTALLATION ON SCREED

1. Prepare a mix of gravel and crushed stone layer of 10cm then proceed with a concrete casting.
2. Prepare a screed of at least 5cm, with the option of a welded mesh installed at 2/3 of the screed thickness.
3. Glue the pavers with a double spread of an exterior-rated elastic adhesive.
4. It is suggested to install the pavers with a minimum 5mm joint, using the proper mortar.
5. Every 9-16 sqm, depending on the surface dimensions and appearance, it could be necessary to add some extension joints not smaller than 5mm.

SISTEMI DI POSA

installation systems



POSA SOPRAELEVATA

1. Al di sopra del solaio predisporre un massetto con una pendenza del 2%, su cui applicare uno strato di impermeabilizzazione. Stendere una guaina drenante che permetta il deflusso delle acque piovane verificandone la tenuta idonea a sopportare i carichi e le sollecitazioni previste dallo specifico utilizzo.
2. Appoggiare direttamente i supporti al di sopra dello strato di drenaggio.
3. Durante la posa regolare ciascun supporto per ottenere un pavimento planare.
4. La fuga tra le piastrelle è definita dallo spessore dei distanziatori posti sulla sommità del supporto, ed è uguale a circa 3 mm.

RAISED LAYING

1. Prepare a screed with a 2% slope over the floor, and then install the waterproof layer: place the draining sheath that allows the outflow of the rainwater, after checking it can stand the loads and pressures of its specific use.
2. Position the pedestals according to the chosen size, over the waterproof layer.
3. During the installation, adjust each pedestals to obtain a flat floor.
4. The joint is determined by the space that are on top of the pedestals, that is 3mm.

LASTRA 80x80 32"x32"

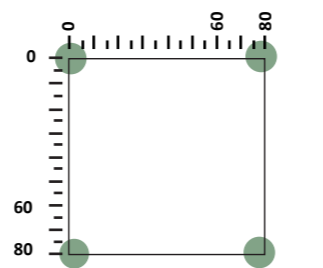

LASTRA 60x90 24"x36"

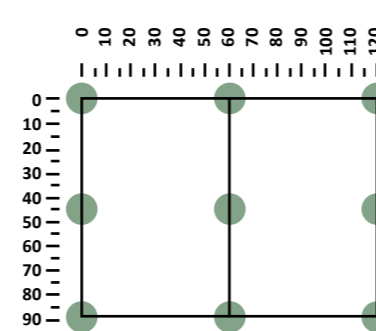

LASTRA 60x60 24"x24"

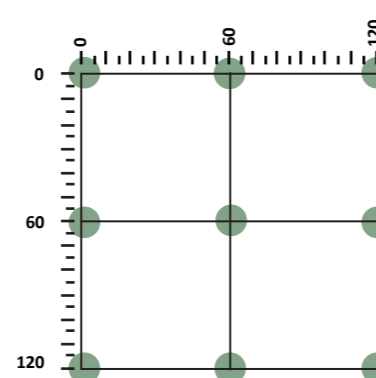

incidenza dei supporti al mq
support incidence to mq

FORMA-TO SIZE	20	30	40	45	50	60	70	75	80	90	100
20	25	16,67	12,5	11,11	10	8,33	14,29	13,33	12,5	11,11	10
30	16,67	11,11	8,33	7,41	6,67	5,56	9,52	8,89	8,33	7,41	6,67
40	12,5	8,33	6,5	5,56	5	4,17	7,14	6,67	6,65	5,56	5
45	11,1	7,41	5,56	4,94	4,44	3,7	6,35	5,63	5,56	4,94	4,44
50	10	6,67	5	4,44	4	3,33	5,71	5,33	5	4,44	4
60	8,3	5,56	4,17	3,7	3,33	2,78	4,76	4,44	4,17	3,7	3,33
70	14,29	9,52	7,14	6,35	5,71	4,76	4,08	3,81	3,57	3,17	2,86
75	13,33	8,89	6,67	5,93	5,33	4,44	3,81	3,56	3,33	2,96	2,67
80	12,5	8,33	6,25	5,56	5	4,17	3,57	3,33	6,25	5,56	5
90	11,11	7,41	5,56	4,94	4,44	3,7	3,17	2,96	5,56	4,94	4,44
100	10	6,67	5	4,44	4	3,33	2,86	2,67	5	4,44	4
120	8,33	5,56	4,17	3,7	3,33	2,78	2,38	2,22	4,17	3,7	3,33

N.B.

Questa tabella è un puro calcolo matematico e non tiene conto di tutte le variabili di cantiere pertanto i valori di incidenza sono indicativi e consigliamo di rivolgersi sempre ai nostri tecnici. This table is a pure mathematical calculation and does not take into account all the site variables so the incidence values are indicative and we recommend always contacting our technicians.

POSA PLUS SOPRAELEVATA 30 mm
RAISED LAYING INSTALLATION
PLUS 30 mm

POSA PLUS SU ERBA 30 mm
INSTALLATION ON GRASS
PLUS 30mm

 **YouTube**
GAMBINI GROUP S.P.A

SUBSCRIBE 



Indicazioni di posa

Laying instructions

CONSIGLI E INDICAZIONI TECNICHE

NELLA POSA DI MATERIALI CERAMICI DI MONOCOTTURA E GRES PORCELLANATO IN ESTERNI, NON POSSONO ESSERE DISATTESE ALCUNE FONDAMENTALI NORME DI POSA PER RENDERE IMPECCABILI ED INATTACABILI DAL GELO LE STRUTTURE PAVIMENTATE. I PUNTI E I PARAMETRI PIÙ IMPORTANTI SONO:

- PENDENZA: È NECESSARIO GARANTIRE AL PAVIMENTO UNA PENDENZA MINIMA DEL 2% (2 CM DI ABBASSAMENTO PER OGNI METRO LINEARE).
- USO DEI GIUNTI DI DILATAZIONE: PER COMPENSARE LA DILATAZIONE AL CALORE OD IL RITIRO DOVUTO AL RAFFREDDAMENTO È CONSIGLIATO, OGNI 3 METRI LINEARI, L'USO DI GIUNTI DI DILATAZIONE CHE ATTRAVERSINO LO STRATO PORTANTE, FINO ALLO STRATO DI IMPERMEABILIZZAZIONE. PER IL RIPIEMIMENTO DEI GIUNTI, VENGONO UTILIZZATI MATERIALE ESPANSO E MATERIALE ISOLANTE.
- STRATO DI SCORRIMENTO: HA LO SCOPO DI EVITARE TENSIONI E DANNI ALLO STRATO DI IMPERMEABILIZZAZIONE.
- STRATO DI IMPERMEABILIZZAZIONE: HA LO SCOPO DI EVITARE LA RISALITA DI UMIDITÀ O ACQUE METEORICHE LIBERE.
- STRATO ISOLANTE TERMICO: DA REALIZZARE UTILIZZANDO MATERIALI REALMENTE ISOLANTI.
- BLOCCO VAPORE: VIENE POSTO SOTTO ALLO STRATO ISOLANTE UTILIZZANDO FOGLI DI PLASTICA, POSATI SOPRA A CARTONI BITUMATI E FORATI.
- ALL'ATTO DELLA POSA CONTROLLARE TONO CALIBRO E SCELTA. IL MATERIALE VIENE DELIBERATAMENTE PRODOTTO E SCELTO CON LEGGERE DIFFERENZE DI TONALITÀ CHE NE SOTTOLINEANO L'EFFETTO CROMATICO. È ASSOLUTAMENTE INDISPENSABILE PRELEVARE PIASTRELLE DA DIVERSE SCATOLE AL MOMENTO DELLA POSA. L'USO DI MATERIALE CHE SIA DIFFORME DALL'ORDINE O DIFETTOSO IMPLICA L'ACCETTAZIONE DELLE CARATTERISTICHE QUALITATIVE ED ESCLUDE CONTESTAZIONI. NON SI ACCETTANO CONTESTAZIONI RELATIVE A MATERIALE GIÀ POSATO.

RECOMMENDATIONS AND TECHNICAL INDICATIONS

THE OUTDOOR LAYING OF SINGLE-FIRED CERAMIC PRODUCTS MUST COMPLY WITH CERTAIN FUNDAMENTAL STANDARDS SO THAT THE FLOORING MAY BE FLAWLESS AND RESISTANT TO FROST. THE MOST IMPORTANT POINTS AND PARAMETERS ARE THE FOLLOWING:

- SLOPE: THE FLOOR MUST HAVE A MINIMUM SLOPE OF 2 % (2 CM OF LOWERING FOR EACH LINEAR METRE).
- USE OF EXPANSION JOINTS: TO COMPENSATE THE EXPANSION DUE TO HEAT OR THE SHRINKING DUE TO FROST, WE RECOMMENDED THAT, EVERY 3 METRES, EXPANSION JOINTS ARE USED THAT PASS OVER THE BEARING LAYER, UP TO THE WATERPROOF LAYER: EXPANDED MATERIAL AND INSULATING MATERIAL ARE USED FOR FILLING THE JOINTS.
- SEPARATING LAYER: USED FOR PREVENTING TENSION AND DAMAGE TO THE WATERPROOF LAYER.
- DAMP-PROOF COURSE: USED FOR PREVENTING HUMIDITY AND WATER FROM COMING THROUGH.
- TERMAL INSULATION LAYER: TO BE MADE WITH INSULATING MATERIALS.
- WATER BARRIER: PLACED UNDER THE INSULATING LAYER USING SHEETS OF PLASTIC LAID OVER BITUMIZED PERFORATED CARDBOARD.
- WHEN SETTING THE TILES, PLEASE CHECK TONE, CALIBER AND CHOICE. OUR MATERIAL IS DELIBERATELY PRODUCED AND CHOSEN WITH SLIGHT DIFFERENCES IN SHADE WHICH UNDERLINE THE COLOUR EFFECTIT IS ABSOLUTELY NECESSARY TO USE TILES FROM DIFFERENT BOXES WHEN INSTALLING. THE USE OF MATERIAL DIFFERENT FROM THE ORDER OR DEFECTIVE MEANS ACCEPTANCE OF THE QUALITY CHARACTERISTICS OF THE GOODS AND EXCLUDES COMPLAINTS. COMPLAINTS ABOUT MATERIAL ALREADY INSTALLED WILL NOT BE ACCEPTED.

Imballi e pesi

Packing and weights

FORMATO / SIZE				Pezzi / scatola Pcs / box	Mq / scatola Sqm / box	KG / scatola KG / box	Colli / paletta Boxes / pallet	Mq / paletta Sqm / pallet
60x60 plus	24"x24"	Ret	20 mm	2	0,72	32,45	30	21,60
60x90 plus	24"x36"	Ret	20 mm	1	0,54	23,50	45	24,30
80x80 plus	32"x32"	Ret	20 mm	2	1,28	56,50	18	23,04
60x60 plus	24"x24"	Ret	30 mm	2	0,72	48,00	20	14,40
80x80 plus	32"x32"	Ret	30 mm	1	0,64	42,00	24	15,36

N.B.

Gli imballi sono puramente indicativi e sono da verificare per ogni singolo formato.
The packing details are a merely indicative reference to be verified for each size.

Caratteristiche tecniche Technical specifications



	SPESSORE	ASSORBIMENTO D'ACQUA	CARICO DI ROTTURA	RESISTENZA AGLI SBALZI TERMICI	RESISTENZA AL GELO	RESISTENZA CHIMICA	RESISTENZA ALLE MACCHIE	COEFFICIENTE DINAMICO DI FRIZIONE	RESISTENZA ALLO SCIVOLAMENTO
	THICKNESS	WATER ABSORPTION	MODULUS OF RUPTURE	RESISTANCE TO THERMAL SHOCK	FROST RESISTANCE	CHEMICAL RESISTANCE	STAIN RESISTANCE	DYNAMIC COEFFICIENT OF FRICTION	SLIP RESISTANCE
		ISO 10545-3 B1a	ISO 10545-4	ISO 10545-9	ISO 10545-12	ISO 10545-13	ISO 10545-14	DCOF	DIN 51130 DIN 51097
								DCOF	
ASGARD plus	20	< 0,5 %	Conforme Compliant	Garantita Guaranteed	Garantita Guaranteed	Conforme Compliant	Conforme Compliant	≥ 0,42	R11
BET plus	20	< 0,5 %	Conforme Compliant	Garantita Guaranteed	Garantita Guaranteed	Conforme Compliant	Conforme Compliant	≥ 0,42	R11
BLUE LABEL plus	20	< 0,5 %	Conforme Compliant	Garantita Guaranteed	Garantita Guaranteed	Conforme Compliant	Conforme Compliant	≥ 0,42	R11
BORDEAUX plus	20	< 0,5 %	Conforme Compliant	Garantita Guaranteed	Garantita Guaranteed	Conforme Compliant	Conforme Compliant	≥ 0,42	R11
HEMISPHERE plus	20	< 0,5 %	Conforme Compliant	Garantita Guaranteed	Garantita Guaranteed	Conforme Compliant	Conforme Compliant	≥ 0,42	R11
MATERIA plus	20	< 0,5 %	Conforme Compliant	Garantita Guaranteed	Garantita Guaranteed	Conforme Compliant	Conforme Compliant	≥ 0,42	R11
OCEAN BLACK plus	20	< 0,5 %	Conforme Compliant	Garantita Guaranteed	Garantita Guaranteed	Conforme Compliant	Conforme Compliant	≥ 0,42	R11
TREVI plus	20	< 0,5 %	Conforme Compliant	Garantita Guaranteed	Garantita Guaranteed	Conforme Compliant	Conforme Compliant	≥ 0,42	R11
UNIKA plus	20 30	< 0,5 %	Conforme Compliant	Garantita Guaranteed	Garantita Guaranteed	Conforme Compliant	Conforme Compliant	≥ 0,42	R11
XO plus	20 30	< 0,5 %	Conforme Compliant	Garantita Guaranteed	Garantita Guaranteed	Conforme Compliant	Conforme Compliant	≥ 0,42	R11

* Secondo la norma EN 14411 (ISO 13006) metodi di prova UNI EN ISO 10545 Appendice G per piastrelle ceramiche pressate a secco a basso assorbimento d'acqua E≤0,5% Gruppo B1a.

Following the EN 14411 (ISO 13006) norms and test cases UNI EN ISO 10545 appendix G for ceramic tiles dry pressed with low water absorption E≤0,5% group B1a.
Selon les normes EN 14411 (ISO 13006) méthodes d'essais UNI EN ISO 10545 Appendice G pour carreaux céramiques pressés à sec, à basse absorption d'eau E≤0,5% groupe B1a.
Nach der Norm EN 14411 (ISO 13006) Prüfmethode UNI EN ISO 10545 Zulage G für trockengepresste Fliesen mit niedriger Wasseraufnahme E≤0,5% Gruppe B1a.

Le caratteristiche tecniche indicate nei cataloghi di linea e nel Catalogo Generale, e in qualsiasi documento di promozione commerciale di GAMBINI GROUP S.p.A., hanno lo scopo di dare un'indicazione dei valori riscontrati nei vari lotti e nelle varie tonalità del prodotto, pertanto differenze rispetto a tali valori indicativi non possono essere oggetto di contestazione.

All technical features stated in leaflets, in master brochure and in merchandising of GAMBINI GROUP S.p.A. are meant to be an indication of an average of figures recorded within a span determined by international law) in several production runs, therefore a slight discrepancy in quality figures of a certain batch in relation to these figures cannot be considered a production failure.

Les caractéristiques techniques mentionnées dans les catalogues de ligne et dans le catalogue général et dans tous les documents de promotion commerciale de GAMBINI GROUP S.p.A. ont le but de fournir une indications des valeurs rencontrés dans les différents lots et dans les différentes tonalités du produit et donc les différences par rapport à ces valeurs indicatives ne peuvent pas faire l'objet des réclamations.

Die in den Linienkatalogen und im Gesamtkatalog sowie in den Werbedokumenten für GAMBINI GROUP S.p.A. angegebenen technischen Merkmale sollen einen Hinweis auf die Werte geben, die in den verschiedenen Chargen und in den verschiedenen Produktfarben gefunden wurden, weshalb sich diese unterscheiden Richtwerte können nicht bestritten werden.

CONDIZIONI GENERALI DI VENDITA

ART. 1 ORDINAZIONI: LE COMMISSIONI, EVENTUALI VARIAZIONI, SCONTI, ESAZIONI, TRATTATIVE DI ABBUONI E TRANSAZIONI CONCLUSE O ACCORDATE CON AGENTI O INTERMEDIARI SI INTENDONO VALIDE CON L'ACCETTAZIONE SCRITTA DA PARTE DELLA VENDITRICE.

ART. 2 PREZZI: I PREZZI SI INTENDONO AL NETTO, PER CONTANTI E PER CONSEGNA FRANCO STABILIMENTO, SALVA DIVERSA PATTUIZIONE. IN CASO DI AUMENTO DEI COSTI DELLE MATERIE PRIME, DELLA MANO D'OPERA, DI PRODUZIONE, DI TRASPORTO E DEI COMBUSTIBILI LA VENDITRICE SI RISERVA LA FACOLTÀ DI AUMENTARE IL PREZZO CONVENUTO SINO ALLA DATA DI CONSEGNA DELL'ORDINAZIONE. QUALORA DETTI COSTI COMPORTINO AI SENSI DELL'ART. 1467 C.C. UN AUMENTO DEL PREZZO CONVENUTO AL MOMENTO DELL'ORDINAZIONE DI OLTRE IL 20%, IL COMPRATORE AVRÀ IL DIRITTO DI DOMANDARE LA RISOLUZIONE DEL CONTRATTO MEDIANTE RACCOMANDATA CON AVVISO DI RICEVIMENTO DA FARE PERVENIRE PRESSO LA SEDE LEGALE DELLA VENDITRICE ENTRO IL TERMINE PERENTORIO DI 10 GIORNI DALL'AVVISO DI AUMENTO DEL PREZZO.

ART. 3 CONSEGNE: I TERMINI DI CONSEGNA INDICATI IN CONTRATTO NON SONO ESSENZIALI E LA VENDITRICE SI RISERVA LA FACOLTÀ DI PROROGARLI LIBERAMENTE, SENZA CHE IL COMPRATORE POSSA ECCEPIRE LA RISOLUZIONE DEL CONTRATTO PER INADEMPIMENTO O PRETENDERE UN RISARCIMENTO DANNI.SOLTANTO DECORSI 60 GIORNI DAL TERMINE DI CONSEGNA INDICATO IL COMPRATORE AVRÀ IL DIRITTO DI RECEDERE DAL CONTRATTO MEDIANTE RACCOMANDATA CON AVVISO DI RICEVIMENTO DA FARE PERVENIRE PRESSO LE SEDI DELLA VENDITRICE ENTRO E NON OLTRE LA DATA DI EFFETTIVA

CONSEGNA, RESTANDO ESCLUSO OGNI RISARCIMENTO DANNI IN SUO FAVORE.

ART. 4 SPEDIZIONI: LA CONSEGNA DEL MATERIALE SI INTENDE PERFEZIONATA CON IL DEPOSITO DELLO STESSO PRESSO LO STABILIMENTO DELLA VENDITRICE. SE IL CONTRATTO CONCLUSO PRESUPPONE IL TRASPORTO DEL MATERIALE FRANCO DESTINO, LA VENDITRICE SI INTENDERÀ LIBERATA DALL'OBLIGO DELLA CONSEGNA E DA OGNI RESPONSABILITÀ RIMETTENDO IL MATERIALE AL VETTORE O ALLO SPEDIZIONIERE AI SENSI DELL'ART. 1693 C.C. . DA QUEL MOMENTO OGNI RISCHIO E PERICOLO DEL TRASPORTO GRAVERÀ ESCLUSIVAMENTE SUL COMPRATORE, SUL QUALE RICADRÀ IL DOVERE AI SENSI DEGLI ARTT. 1697 E 1698 C.C. DI VERIFICARE IL MATERIALE TRASPORTATO PRIMA DI ACCETTARLO E DI SOLLEVARE EVENTUALI RISERVE AL VETTORE O SPEDIZIONIERE LADDOVE RISCONTRASSE PERDITE O AVARIE, ROTTURE O MANCANZE, DI CUI LA VENDITRICE NON SARÀ RESPONSABILE.

ART. 5 PAGAMENTI: L'OBLIGAZIONE DI PAGAMENTO DEVE ESSERE SEMPRE ADEMPIUTA IN CONTANTI PRESSO LA SEDE LEGALE DELLA VENDITRICE. OGNI CLAUSOLA CONTRATTUALE CHE PREVEDA IL PAGAMENTO DEL PREZZO IN ALTRO LUOGO O MEDIANTE TITOLI DI CREDITO QUALI CAMBIALI TRATTE O PAGHERÒ CAMBIARI DEVE INTENDERSI PRESTAZIONE IN LUOGO DELL'ADEMPIMENTO EX ART. 1197 C.C. ED È ESCLUSIVAMENTE INTESA AD AGEVOLARE IL CORRETTO E TEMPESTIVO PAGAMENTO DEL COMPRATORE, SENZA CHE ESSA DEROGHI AL LUOGO DELL'ADEMPIMENTO, CHE RESTA LA SEDE DELLA VENDITRICE. LE IMPOSTE DI BOLLO E LE COMMISSIONI DI INCASSO DEI TITOLI DI CREDITO SONO A CARICO DEL COMPRATORE. DECORSI 10 GIORNI DALLA SCADENZA DEL TERMINE DI PAGAMENTO LA VENDITRICE SI RISERVA IL DIRITTO DI EMETTERE SENZA PREAVVISO E CON SPESE A CARICO DEL COMPRATORE CAMBIALE TRATTA A VISTA PER L'IMPORTO IMPAGATO.

ART. 6 RISERVATO DOMINIO: LA VENDITA SI INTENDE CON RISERVA DELLA PROPRIETÀ EX ART. 1523 C.C.

IL COMPRATORE ACQUISTERÀ LA PROPRIETÀ DEL MATERIALE CON IL PAGAMENTO DELL'INTERO PREZZO, COMPRESI EVENTUALI INTERESSI ED ACCESSORI DI LEGGE. SINO A QUEL MOMENTO LA PROPRIETÀ DEL MATERIALE RESTERÀ IN CAPO ALLA VENDITRICE.

ART. 7 INTERESSI DI MORA: LA VENDITRICE HA DIRITTO AD ESIGERE IL PAGAMENTO DEGLI INTERESSI MORATORI PREVISTI IN CASO DI RITARDATO PAGAMENTO NELLE TRANSAZIONI COMMERCIALI AI SENSI DEL D.LGS. N. 231 DEL 9 OTTOBRE 2002 E SUCCESSIVE MODIFICHE IN DIFETTO DI PAGAMENTO NEL TERMINE E NEL LUOGO DI ADEMPIMENTO CONTRATTUALMENTE PREVISTO.

ART. 8 CLAUSOLA RISOLUTIVA: IL MANCATO PAGAMENTO DEL PREZZO, ANCHE SOLTANTO PARZIALE E LA SUSSISTENZA DEI RISCHI DI INSOLVENZA, ANCHE SOLO APPARENTE O IL TARDIVO PAGAMENTO DI 8 GIORNI DETERMINA LA RISOLUBILITÀ DEL CONTRATTO PER INADEMPIMENTO DEL COMPRATORE, CON

CONSEQUENTE DIRITTO DELLA VENDITRICE DI RIFIUTARSI DI ADEMPIERE LA SUA OBBLIGAZIONE E, IN PARTICOLARE, DI EFFETTUARE LE FORNITURE NON ANCORA ESEGUITE.

ART. 9 SOLVE ET REPETE: IL COMPRATORE NON POTRÀ OPPORRE ECCEZIONI, NESSUNA ESCLUSA, COMPRESI PRETESI VIZI O DIFETTI DEL MATERIALE, AL FINE DI EVITARE, RITARDARE O SOSPENDERE IL PAGAMENTO DELLA FORNITURA. RESTA SALVA LA SOLA FACOLTÀ DEL COMPRATORE DI RIPETERE CIÒ CHE HA INDEBITAMENTE PAGATO, PREVIO ASSOLVIMENTO DEL RELATIVO ONERE PROBATORIO.

ART. 10 RECLAMI E GARANZIE: LA VENDITRICE NON PRENDERÀ IN CONSIDERAZIONE I RECLAMI CHE NON DOVESSERO PERVENIRE DIRETTAMENTE PRESSO LA PROPRIA SEDE LEGALE ENTRO IL TERMINE DI 8 GIORNI. LA GARANZIA PER EVENTUALI VIZI O DIFETTI NON SI APPLICA AL MATERIALE GIÀ POSATO, A QUELLO DI QUALITÀ INFERIORE ALLA PRIMA SCELTA E IN PARTICOLARE AL MATERIALE DI SECONDA E TERZA SCELTA DI STOCK.LA VENDITRICE NON RISPONDE IN NESSUN CASO DEI VIZI DOVUTI ALL'USO AL QUALE IL COMPRATORE INTENDE DESTINARE IL MATERIALE ACQUISTATO, NEPPURE IN PRESENZA DI SUGGERIMENTI O CONSIGLI DELLA VENDITRICE STESSA CIRCA L'INSTALLAZIONE DEL MATERIALE. LA VENDITRICE SI RISERVA LA FACOLTÀ DI AUTORIZZARE LA RESTITUZIONE DEL MATERIALE, SU ESPRESSA RICHIESTA DEL COMPRATORE.

ART. 11 DECADENZA DELLA GARANZIA: IL COMPRATORE DOVRÀ CONTROLLARE ACCURATAMENTE OGNI SINGOLO COLLO DEL MATERIALE ACQUISTATO AL MOMENTO DEL SUO RICEVIMENTO. QUALORA RISCONTRASSE VIZI O DIFETTI APPARENTI E COPERTI DALLA GARANZIA, IL COMPRATORE DOVRÀ DENUNZIARLI OBBLIGATORIAMENTE ALLA VENDITRICE MEDIANTE RACCOMANDATA CON AVVISO DI RICEVIMENTO DA FARE PERVENIRE PRESSO LE SUE SEDI LEGALI ENTRO IL TERMINE PERENTORIO DI 8 GIORNI DALLA CONSEGNA DEL MATERIALE. DECORSO TALE TERMINE IL COMPRATORE SI INTENDERÀ DECADUTO DAL DIRITTO ALLA GARANZIA PER EVENTUALI VIZI O DIFETTI DEL MATERIALE CONSIDERATI APPARENTI A PARERE DI UN ESPERTO. IL COMPRATORE CHE ABBIA VALIDAMENTE ATTIVATO LA GARANZIA PER PRETESI VIZI DOVRÀ TENERE A DISPOSIZIONE DELLA VENDITRICE L'INTERA PARTITA DEL MATERIALE; IN DIFETTO, OVE NE DISPONGA, ANCHE IN PARTE, SI INTENDERÀ DECADUTO DA OGNI GARANZIA.

ART. 12 FORO: PER OGNI CONTROVERSIA RELATIVA ALLA FORNITURA CHE DOVESSE SORGERE TRA LA VENDITRICE E IL COMPRATORE SARÀ COMPETENTE IN VIA ESCLUSIVA L'AUTORITÀ GIUDIZIARIA DEL FORO DI MODENA, SALVA DIVERSA DESIGNAZIONE DA PARTE DELLA VENDITRICE.

ART. 13 DISCIPLINA APPLICABILE: I RAPPORTI COMMERCIALI CON LA VENDITRICE SARANNO REGOLATI DALLA LEGGE ITALIANA.

AL CONTRATTO SI APPLICHERANNO TUTTE LE NORME, CONDIZIONI E PRESCRIZIONI STABILITE NELLO STESSO E DALLE PRESENTI CONDIZIONI GENERALI DI VENDITA. PER TUTTO QUANTO NON ESPRESSAMENTE PREVISTO O REGOLAMENTATO, SI RINVIA ALLA DISCIPLINA DETTATA DAL CODICE CIVILE E DALLE ALTRE NORME VIGENTI IN MATERIA DI VENDITA.

AI SENSI E PER GLI EFFETTI DEGLI ART. 1341 E 1342 C.C. IL COMPRATORE DICHIARA DI APPROVARE ESPRESSAMENTE E SPECIFICAMENTE PER ISCRITTO GLI ARTICOLI 2, 3, 4, 8, 11 E 12.

GENERAL TERMS AND CONDITIONS OF SALE

PURCHASE ORDERS

ANY PURCHASE ORDERS OR OTHER VARIATIONS OF THE SALE CONDITIONS, ALLOWANCES, NEGOTIATIONS, DISCOUNTS, TRANSACTIONS ETC. EVEN IF MADE ON THE INITIATIVE OF THE AGENT OR OTHER INTERMEDIARIES WILL ONLY BE BINDING UPON OUR WRITTEN CONFIRMATION.

PRICES

PRICES ARE TO BE CONSIDERED CASH AND EX FACTORY DELIVERED, UNLESS OTHERWISE STATED. SHOULD ANY RAW MATERIAL, LABOUR, FUEL, PRODUCTION EXPENSE, TRANSPORT ETC. BE SUBJECT TO ANY COST INCREASE BETWEEN THE DATE OF THE PURCHASE ORDER AND THE DATE OF DELIVERY, THE SELLER SHALL RESERVE THE RIGHT TO INCREASE THE PRICE ACCORDINGLY. SHOULD SAID PRICE EXCEED THE 20% OF THE PREVIOUSLY AGREED PRICE, THE PURCHASER SHALL RESERVE THE RIGHT TO WITHDRAW FROM THE CONTRACT BY SENDING WRITTEN NOTICE BY REGISTERED LETTER WITHIN 10 DAYS OF HAVING RECEIVED THE PRICE INCREASE NOTICE.

TERMS OF DELIVERY

DELIVERY DATE IS TO BE CONSIDERED PURELY INDICATIVE AND NOT BINDING AND THE EXTENSION OF SAID DATE SHALL NOT ALLEGE TO THE PURCHASER ANY INDEMNITY NOR PURCHASE ORDER CANCELLATION WITH ANY EXCEPTION. ONLY IN THE EVENT THAT THE DELAY EXCEEDS 60 DAYS, THE PURCHASER SHALL HAVE THE RIGHT TO WITHDRAW FROM THE CONTRACT. IN SUCH CASE, THE DECLARATION OF WITHDRAWAL SHALL BE SENT TO THE COUNTERPART BY REGISTERED LETTER AND ANY INDEMNITY OR COMPENSATION IS EXCLUDED.

DELIVERY

THE PURCHASER UNDERTAKES TO VERIFY AND CHECK GOODS QUALITY AND AMOUNT BEFORE COLLECTION AND AFTER THE PURCHASER HAS INSPECTED THE GOODS, ANY CLAIMS SHOULD BE MADE TO THE CARRIER.

PAYMENT

PAYMENT IS TO BE REMITTED TO OUR REGISTERED OFFICES. SHOULD THE SALE CONTRACT FORESEE A DIFFERENT KIND OF PAYMENT INCLUDING THE ISSUE OF BILLS OF EXCHANGE OR BANK DRAFTS, THE AFOREMENTIONED REGULATIONS SHALL NOT BE MODIFIED AND PAYMENT SHALL BE ALWAYS REMITTED TO OUR REGISTERED OFFICE. ANY TAX AND COLLECTION OF BILLS EXPENSE SHALL BE BORN BY THE PURCHASER. ISSUE OF DRAFTS

DELAYED PAYMENT OF OUR INVOICED AFTER 10 DAYS FROM THE STIPULATED DUE DATE SHALL ENTITLE US TO THE IMMEDIATE ISSUE OF DRAFTS PAYABLE AT SIGHT WITH NO TIME NOTICE.

CONDITION OF OWNERSHIP

PURSUANT TO ARTICLES 1523 AND FOLLOWING OF THE CIVIL CODE, ALL PRODUCTS, ACCESSORIES AND ANY RELEVANT INTERESTS, SHALL REMAIN EXCLUSIVE PROPERTY OF THE SELLER UNTIL FULL PAYMENT OF THE AGREED PRICE.

INTERESTS ON ARREARS

STARTING FROM THE STIPULATED DUE DATE OF PAYMENT THE CURRENT INTERESTS ON ARREARS SHALL BECOME EFFECTIVE.

CANCELLATION

NON-PAYMENT, FULLY OR IN PART, OF THE SUPPLIED GOODS OR ANY DELAYED PAYMENT AFTER 8 DAYS SHALL GIVE US THE RIGHT TO WITHDRAW FROM THE CONTRACT AND NOT TO DELIVER THE REMAINING SUPPLY, SAID RIGHT COULD BE EXERCISED ALSO IN CASE OF INSOLVENCY, REAL OR DEEMED, OF THE PURCHASER.

SOLVE ET REPETE

IN NO CASE, DAMAGE OR FAULTS OF THE GOODS INCLUDED, SHALL THE PURCHASER HAVE THE RIGHT TO DELAY OR SUSPEND THE PAYMENT OF COLLECTED MATERIALS, SAVE FOR THE RIGHT TO DEMONSTRATE TO HAVE PAID UNDUE AMOUNTS.

CLAIMS AND WARRANTY

ALL CLAIMS SHALL BE COMMUNICATED WITHIN 8 DAYS FROM DELIVERY OF THE GOODS TO DESTINATION. THE PURCHASER CLAIMING WITHIN THIS TIME SHALL MAKE THE CLAIMED GOODS AVAILABLE TO THE SELLER FOR HIS/HER VERIFICATION AND CHECK. IN THE EVENT THAT DAMAGES OR LOSSES ARE EFFECTIVE, ONLY FAULTY AND DAMAGED MATERIALS WILL BE REPLACED AND IN NO CASE SHALL THE SELLER BE CHARGEABLE WITH ANY COST OR INDEMNITY. THE REFUND VALUE SHALL NOT BE MORE THAN THE WORTH OF THE PRODUCT PLUS SHIPMENT CHARGES. ACCEPTABLE CLAIMS REFER TO "FIRST QUALITY" PRODUCTS ONLY, EXPRESSLY EXCLUDING ANY CLAIMS FOR SECOND, THIRD OR STOCK QUALITY PRODUCTS. NO CLAIMS SHALL BE ACCEPTED AFTER THE PRODUCTS HAVE ALREADY BEEN INSTALLED. EVERY INSTALLATION OF THE MATERIAL, BE IT TOTAL OR PARTIAL, CONSTITUTES AN UNCONDITIONAL ACCEPTANCE OF THE GOODS AS CORRESPONDING TO WHAT WAS AGREED IN THE ORDER CONFIRMATION. THE SELLER SHALL NOT BE LIABLE FOR ANY DESTINATIONS OF USE OF THE PRODUCT CHOSEN BY THE PURCHASER, NEITHER IN THE EVENT OF SELLER'S SUGGESTIONS AND RECOMMENDATIONS OF INSTALLATION. THERE IS NO FURTHER WARRANTY OTHER THAN THAT WHICH IS DERIVED FROM THE DESCRIPTION OF THE GOODS AS INDICATED IN THE ORDER CONFIRMATION, CATALOGUES AND COMPANY'S LITERATURE. FURTHERMORE, NO IMPLICIT WARRANTY IS OFFERED FOR A PARTICULAR USE OF THE PRODUCT. THE PURCHASER AGREES THAT THE GOODS ARE SOLD AS "SEEN AND ACCEPTED." UPON PREVIOUS ACCEPTANCE, THE SELLER SHALL ONLY BE LIABLE FOR RETURNING OF THE GOODS. IN THAT CASE WE WILL TAKE CARE ONLY OF THE TRANSPORTATION FEES AND NO FURTHERMORE.

WARRANTY INVALIDATION

UPON RECEIVING THE GOODS, THE PURCHASER UNDERTAKES TO CAREFULLY CHECK THEM OPENING THE BOXES. IN THE EVENT THAT THE PURCHASER IDENTIFIES DAMAGES COVERED BY OUR WARRANTY, HE/SHE SHALL COMMUNICATE THIS CLAIM BY REGISTERED LETTER WITHIN 8 DAYS FROM RECEIVING OF THE GOODS. AFTER THIS TIME HAS EXPIRED, THE PURCHASER SHALL NOT HAVE ANY WARRANTY RIGHTS FOR ANY IDENTIFIED DAMAGE. SHALL THE PURCHASER EXERCISE HIS/HER RIGHT TO CLAIM, HE/SHE SHALL MAKE THE WHOLE SUPPLY AVAILABLE TO THE SELLER SHALL THE PURCHASER MAKE AVAILABLE ONLY PART OF THE SUPPLY, THE WARRANTY SHALL BE INVALIDATED.

COURT - APPLICABLE LAW

ANY DISPUTE CONCERNING THE SUPPLY, BEING THAT RAISED BY EITHER THE SUPPLIER OR THE BUYER WILL BE ASSESSED BASED UPON THE APPLICABLE ITALIAN LAW, GIVING EXCLUSIVE COMPETENCE TO RULE TO THE REGGIO EMILIA TRIBUNAL, EXCEPT WHERE OTHERWISE ELECTED BY THE SUPPLIER.

CONDITIONS GENERALES DE VENTE

COMMANDES

TOUTES COMMANDES ET/OU PROPOSITIONS DE COMMANDES, REMISES SUR TARIFS, ÉVENTUELLES VARIATIONS, RECOUVREMENT DE CRÉANCES,

NÉGOCIATIONS, AVOIRS, RISTOURNES, TRANSACTIONS ETC., EFFECTUÉS PAR DES AGENT ET/OU PAR DES INTERMÉDIAIRE NE POURRONT PAS ÊTRE CONSIDÉRÉS VALABLES ET VALIDES SANS UNE CONFIRMATION ÉCRITE DE NOTRE PART.

PRIX

LES PRIX DOIVENT SE CONSIDÉRÉS AU COMPTANT AND POUR DES LIVRAISONS DÉPART USINE, SAUF ACCORDS DIFFÉRENTS. SI ENTRE LA DATE DE LA COMMANDE ET LA DATE DE LA LIVRAISON DE LA COMMANDE IL DEVAIT S'AVÉRER UNE HAUSSE DES COÛTS DES MATIÈRES PREMIÈRES, DE LA MAIN D'ŒUVRE, DES COMBUSTIBLES, DES FRAIS DE PRODUCTION, DE TRANSPORT ETC., LE VENDEUR POURRA AUGMENTER LES PRIX CONVENUS. CEPENDANT SI CETTE HAUSSE DEVAIT ÊTRE SUPÉRIEURE À 20% PAR RAPPORT AUX PRIX CONVENUS, L'ACHETEUR POURRA RÉSILIER LE CONTRAT PAR L'ENVOI D'UNE LETTRE RECOMMANDÉE, NOUS NOTIFIANT AINSI SA VOLONTÉ, DANS LE DÉLAI PÉREMPTOIRE DE 10 JOURS DATE DE RÉCEPTION DE L'AVIS DE HAUSSE DES PRIX.

LIVRAISONS

LES DÉLAIS DE LIVRAISONS SONT TOUJOURS INDICATIFS ET LEUR PROROGATION NE PEUT EN AUCUN CAS DONNER DROIT À UNE INDEMNISATION ET/OU AUTRE REQUÊTE DE LA PART, TOUTE EXCEPTION ÉCARTÉE. SEULEMENT DANS LE CAS OÙ LE RETARD DÉPASSERAIT LES 60 JOURS, L'ACHETEUR POURRA RÉSILIER LE CONTRAT PAR LETTRE RECOMMANDÉE; RESTE EXCLU TOUT DÉDOMMAGEMENT, QUEL QU'IL SOIT, EN SA FAVEUR.

EXPEDITIONS

LA MARCHANDISE VOYAGE AUX RISQUES ET PÉRILS DE L'ACHETEUR ET DOIT S'ENTENDRE DÉPART USINE ET LE VENDEUR DÉCLINANT TOUTE RESPONSABILITÉ MÊME DANS LE CADRE D'UNE LIVRAISON FRANCO DESTINATION. L'ACHETEUR A L'OBLIGATION DE VÉRIFIER L'ÉTAT DU MATÉRIEL AVANT SON ENLÈVEMENT, PRÉSENTANT SES RÉCLAMATIONS À QUI DE DROIT AU CAS OÙ AIENT ÉTÉ RELEVÉS DES DOMMAGES OU DES DIFFÉRENCES DANS LES QUANTITÉS DONT LE VENDEUR NE PEUT ÊTRE APPELÉ EN CAUSE.

REGLEMENTS

LE LIEU DE RÈGLEMENT EST DOMICILIÉ ET ÉLU EXCLUSIVEMENT AUPRÈS DE NOTRE SIÈGE LÉGAL MÊME DANS LE CAS OÙ LE CONTRAT INDIQUERAIT UN LIEU DIFFÉRENT OU PAR ÉMISSION DE TRAITES OU LETTRES DE CHANGE, LES RELATIVES CLAUSES NE VISENT QU'À FACILITER LE RÈGLEMENT DE LA PART DE L'ACHETEUR, MAIS NE COMPORTENT PAS LE DÉPLACEMENT DU LIEU MÊME QUI RESTE DOMICILIÉ ET ÉLU AUPRÈS DE NOTRE SIÈGE. LES FRAIS D'ENCAISSEMENT S ET LÉGAUX POUR LES TRAITES ET LES LETTRES DE CHANGE SONT À LA CHARGE DE L'ACHETEUR. FACULTE D'ÉMISSION DE TRAITES

NOUS SERONS AUTORISÉS À ÉMETTRE DES TRAITES AVEC RÈGLEMENT À VUE ET TOUS LES FRAIS DÉRIVANTS À LA CHARGE DE L'ACHETEUR, SI PASSÉS 10 JOURS APRÈS L'ÉCHÉANCE CONVENUE ET CONCORDÉE, LE RÈGLEMENT DE LA FACTURE NE NOUS SERA PAS PARVENU. CIVIL. EN CONSÉQUENCE, LES MARCHANDISES RESTENT LA PROPRIÉTÉ DU VENDEUR ET CE JUSQU'À CE QUE LES SOMMES DUES SOIENT TOTALEMENT RÉGLÉES, Y COMPRIS INTÉRÊTS ET FRAIS ACCESSOIRES.

INTERETS DE RETARD

LES INTÉRÊTS COMMERCIAUX AU TAUX COURANT SERONT RECONNUS AU VENDEUR À DATER DU JOUR D'ÉCHÉANCE CONVENU POUR LE PAIEMENT.

CLAUDE RESOLUTOIRE

EN CAS DE NON RÈGLEMENT, OU MÊME D'UNE SEULE PARTIE DU MATÉRIEL FOURNI, AINSI QU' EN CAS DE RETARD DE 8 JOURS DU RÈGLEMENT QUELQUE SOIT LA FORME DE RÈGLEMENT PRÉVUE, LE VENDEUR AURA LA FACULTÉ DE CONSIDÉRER RÉSILIÉ LE CONTRAT ET IL SERA DE CONSÉQUENCE EXEMPTÉ DE L'OBLIGATION D'EFFECTUER LES LIVRAISONS RESTANTES. IL EN VA DE MÊME EN CAS DE NON SOLVABILITÉ, MÊME APPARENTE, DE L'ACHETEUR.

SOLVE ET REPETE

EN AUCUN CAS, INCLUS DE PRÉTENDUS VICÉS ET DÉFAUTS VISIBLES DU MATÉRIEL, L'ACHETEUR NE POURRA SUSPENDRE OU RETARDER LE RÈGLEMENT DU MATÉRIEL DÉJÀ LIVRÉ, EXCEPTION FAITE POUR SA FACULTÉ DE RÉCLAMER, QUAND IL EST EN MESURE DE LE DÉMONTRER D'AVOIR INDÛMENT PAYÉ.

RECLAMATIONS ET GARANTIE

AUCUNE RÉCLAMATION NE SERA PRISE EN CONSIDÉRATION SI CELLE- CI NE NOUS AURA PAS ÉTÉ DIRECTEMENT FORMULÉE DANS LE DÉLAI DE 8 JOURS À DATER DE LA RÉCEPTION DE LA MARCHANDISE. L'ACHETEUR QUI AURAIT PRÉSENTÉ UNE RÉCLAMATION DANS LES TERMES INDICUÉS, DEVRA GARDER LA TOTALITÉ DU MATÉRIEL LIVRÉ À LA DISPOSITION DU VENDEUR, POUR TOUT CONTRÔLE ; ET AU CAS OÙ DES VICÉS OU DES DÉFAUTS DE QUALITÉ SERAIENT CONSTATÉS, L'ACHETEUR N' AURA DROIT QU' AU REMPLACEMENT DU MATÉRIEL DÉFECTUEUX AVEC L'EXCLUSION DE TOUT DÉDOMMAGEMENT. DE TOUTE

MANIÈRE, TOUT DÉDOMMAGEMENT NE POURRA EN AUCUN CAS EXCÉDER LA VALEUR DU MATÉRIEL FACTURÉ, AVEC LES FRAIS DE TRANSPORT INCLUS. LA GARANTIE S'ENTEND LIMITÉE QU'AU MATÉRIEL DE PREMIER CHOIX, EXCLUANT FORMELLEMENT TOUT MATÉRIEL DE DEUXIÈME CHOIX ET DE TROISIÈME CHOIX AINSI QUE LES LOTS. NE SERA AUCUNEMENT PRISE EN CONSIDÉRATION TOUTE RÉCLAMATION CONCERNANT DU MATÉRIEL DÉJÀ POSÉ. TOUT MATÉRIEL POSÉ, MÊME PARTIELLEMENT , CONSTITUE ACCEPTATION INCONDITIONNELLE DES MATÉRIAUX COMME CONFORMES À CE QUI A ÉTÉ INDICUÉ DANS LA PROPOSITION DE COMMANDE. LA RESPONSABILITÉ DU VENDEUR NE PEUT EN AUCUN CAS ÊTRE ÉTENDUE À L'UTILISATION POUR LAQUELLE L'ACHETEUR ENTENDU DESTINER NOTRE PRODUIT, MÊME SI DE NOTRE PART NOUS AURIONS FOURNI DES SUGGESTIONS OU DES CONSEILS POUR LA POSE DU PRODUIT EN QUESTION. IL N' Y A AUCUNE EXTENSION DE GARANTIE AU DELÀ DE CELLES DÉRIVANT DE LA DESCRIPTION DES BIENS COMME INDICUÉ SUR LA CONFIRMATION DE COMMANDE, DANS LES CATALOGUES ET DANS LA DOCUMENTATION DE L'USINE. IL N'Y A EN OUTRE DE GARANTIE IMPLICITE OU D'APTITUDE DU PRODUIT POUR UN USAGE PARTICULIER IL N'YA ENTRE AUTRE AUCUNE GARANTIE IMPLICITE OU D'APTITUDE DU PRODUIT POUR UNE UTILISATION SPÉCIALE ET L'ACHETEUR PREND NOTE QUE LES BIENS SONT VENDUS COMME

«CHOISIS ET COMMANDÉS». LE RETOUR EN USINE DE LA MARCHANDISE NE POURRA ÊTRE EFFECTUÉE QU'APRÈS AUTORISATION DE NOTRE PART ET NE SERONT RECONNUS À NOTRE CHARGE QUE LES FRAIS DE TRANSPORT SANS AUCUNE AUTRE INDEMNITÉ QUELLE QU'ELLE SOIT.

DECHANCE DE LA GARANTIE

A LA RÉCEPTION DU MATÉRIEL L'ACHETEUR DEVRA LE SOUMETTRE À UN CONTRÔLE PRÉCIS EN OUVRANT LES BOÎTES ; SI IL DEVAIT CONSTATER DES VICÉS OU DES DÉFAUTS APPARENTS ET POUR LESQUELS ŒUVRE NOTRE GARANTIE, L'ACHETEUR DEVRA PRÉSENTER UNE RÉCLAMATION QUI NE SERA CONSIDÉRÉE VALABLE QUE SI ELLE NOUS AURA ÉTÉ TRANSMISE DIRECTEMENT, PAR LETTRE RECOMMANDÉE DANS LE DÉLAI PÉREMPTOIRE DE HUIT JOURS À DATER DE LA RÉCEPTION DU MATÉRIEL. PASSÉ CE DÉLAI L'ACHETEUR SERA CONSIDÉRÉ DÉCHU DES DROITS PRÉVUS PAR CETTE GARANTIE, POUR TOUT DÉFAUT CONSIDÉRÉ APPARENT SELON UN EXPERT. L'ACHETEUR, QUI AURAIT PRÉSENTÉ LA RÉCLAMATION DANS LES TERMES INDICUÉS, DEVRA GARDER LA TOTALITÉ DU MATÉRIEL LIVRÉ À LA DISPOSITION DU VENDEUR; AU CAS OÙ IL N'EN E DISPOSERAIT QUE D'UNE PARTIE, IL SERA DÉCHU DE TOUTE GARANTIE.

TRIBUNAL COMPÉTENT - LOI APPLICABLE

POUR TOUTE CONTESTATION INHÉRENTE DE TOUTE MANIÈRE À LA LIVRAISON, TANT DE LA PART DU VENDEUR QUE DE LA PART DE L'ACHETEUR, LA COMPÉTENCE EXCLUSIVE EST ATTRIBUÉE AU TRIBUNAL DE REGGIO EMILIA AVEC APPLICATION DE LA LOI ITALIENNE, LAISSANT LA FACULTÉ AU VENDEUR DE SAISIR L'AUTORITÉ JUDICIAIRE AUTREMENT COMPÉTENTE.

ALLGEMEINE VERKAUFS- UND LIEFERBEDINGUNGEN

AUFTRÄGE

VON AGENTEN ODER VERMITTLERN DURCHFÜHRTE BESTELLUNGEN, MÖGLICHE ABÄNDERUNGEN, EINTREIBUNGEN, VERHANDLUNGEN, NACHLÄSSE, TRANSAKTIONEN ETC., HABEN OHNE UNSERE SCHRIFTLICHE BESTÄTIGUNG KEINERLEI GÜLTIGKEIT.

PREISE

DIE PREISE VERSTEHEN SICH BAR BEI LIEFERUNG AB WERK, AUSGENOMMEN ANDERS LAUTENDER VEREINBARUNGEN. SOLLTEN SICH ZWISCHEN BESTELLDATUM UND LIEFERDATUM EINE ERHÖHUNG DER ROHSTOFF-, LOHN-, BRENNSTOFF-, PRODUKTIONS- UND TRANSPORTKOSTEN ETC. ERGEBEN, IST DER VERKÄUFER BERECHTIGT DEN VEREINBARTEN PREIS ZU ERHÖHEN. SOLLTE DIE PREISSTEIFERUNG 20% DES BEI BESTELLUNG VEREINBARTEN PREISES ÜBERSTIEGEN, KANN DER KÄUFER INNERHALB EINES UNAUFSCHEBBAREN TERMINS VON 10 TAGEN NACH ERHALT DER MITTEILUNG DER PREISERHÖHUNG, SEINEN WILLEN VOM VERTRAG ZURÜCKTRETEN MITTELS EINSCHREIBEBRIEF MITTEILEN.

LIEFERUNG

DIE LIEFERTERMINE VERSTEHEN SICH IMMER ALS RICHTWERTE UND RÄUMEN - JEDLICHE AUSNAHME AUSGESCHLOSSEN - DEM KÄUFER BEI LIEFERUNGSVERZUG KEIN RECHT AUF SCHADENSERSATZ ODER ÄHNLICHES EIN. LEDIGLICH IM FALLE EINER VERSPÄTUNG VON ÜBER 60 TAGEN KANN DER KÄUFER SCHRIFTLICH MITTELS EINSCHREIBEN SEINE ABSICHT MITTEILEN, DASS ER DEN VERTRAG ALS AUFGELOST BE-TRACHTET: JEDLICHER ANSPRUCH AUF SCHADENSERSATZ ZU SEINEN GUNSTEN BLEIBT AUSGESCHLOSSEN.

VERSAND

DER VERSAND DER WARE ERFOLGT AUF RISIKO UND GEFAHR DES KÄUFERS UND VERSTEHT SICH AB WERKLAGER VERKAUFT. DER VERKÄUF-ER ÜBERNIMMT KEINERLEI HAFTUNG AUCH WENN DAS MATERIAL FREI HOF ANGELIEFERT WIRD. ES OBLIEGT DER PFLICHT DES KÄUFERS DAS MATERIAL VOR ÜBERNAHME ZU ÜBERPRÜFEN. ETWAIGE RÜGEN HINSICHTLICH BRUCH ODER FEHLMENGEN, SIND AN DIE HIERFÜR VERAN- WORTLICHEN ZU RICHTEN, OHNE DASS DADURCH DER VERKÄUFER ZUR VERANTWORTUNG GEZOGEN WERDEN KANN.

ZAHLUNGEN

ZAHLUNGORT SIND UND BLEIBEN AUSSCHLIESSLICH UNSERE RECHTLICHEN GESCHÄFTSSITZE. AUCH IM FALLE, DASS DER VERTRAG DIE ZAHLUNG AN EINEM ANDEREN ORT VORSIEHT, TRATTEN ODER WECHSEL AUSGESTELLT WERDEN, SIND DIE ENTSPRECHENDEN KLAUSELN AUSSCHLIESSLICH DAHINGEHEND ZU VERSTEHEN, DASS DEM KÄUFER DIE ZAHLUNG ERLEICHTERT WERDEN SOLL, JEDOCH DADURCH KEINERLEI VERÄNDERUNG DER RECHTSITZE ALS ERFÜLLUNGORT BEWIRKT WIRD. DIE SPESEN FÜR STEMPELMARKEN, INKASSO- UND TRAT- TEN-VERFAHREN GEHEN ZU LASTEN DES KÄUFERS.

AUSSTELLUNG VON TRATTEN

WIR BEHALTEN UND DAS RECHT VOR, NACH ABLAUF VON 10 TAGEN NACH ZAHLUNGSTERMIN, SICHTTRATTEN ZUR DECKUNG DES VERKAUF-SPREISES MIT BELASTUNG DER SPESEN UND OHNE BESONDERE VORANKÜNDIGUNG AUSZUSTELLEN.

EIGENTUMSVORBEHALT

DIE WAREN WERDEN MIT VORBEHALT DES EIGENTUMS, GEMÄSS ARTIKEL 1523 UND FOLGENDE DES ITALIENISCHEN BGB (CODICE CIVILE) VERKAUFT. FOLGLICH BLEIBEN ALLE WAREN UNSER EIGENTUM, SOLANGE DER KÄUFER DEN GESAMTEN KAUFPREIS, EINSCHLIESSLICH VON ZINSEN UND ALLER NEBENFORDERUNGEN, NICHT VOLLSTÄNDIG BEZAHLT HAT.

VERZUGSZINSEN

AB VEREINBARTEM ZAHLUNGSTERMIN FALLEN DIE HANDELSÜBLICHEN ZINSEN ZU UNSEREN GUNSTEN AN.

AUFHEBUNGSKLAUSEL

IM FALLE EINER AUSSTEHENDEN ZAHLUNG, AUCH NUR HINSICHTLICH EINER ERFOLGTEN TEILLIEFERUNG UND AUCH IM FALLE, DASS DER KÄUFER MIT DER VEREINBARTEN ZAHLUNG (JEDLICHER ART) 8 TAGE IN VERZUG KOMMT, IST DER VERKÄUFER DAZU ERMÄCHTIGT, DEN VER- TRAG ALS AUFGELOST ZU BETRACHTEN UND SICH VON DER PFLICHT ZU ENTBINDEN, DIE NOCH OFFENEN LIEFERUNGEN DURCHZUFÜHREN; DIES GILT AUCH IM FALLE DER INSOLVENZ DES KÄUFERS, AUCH WENN DIESE NUR SCHEINBAR SEIN SOLLTE.

SOLVE ET REPETE

IN KEINEM FALLE, EINSCHLIESSLICH MATERIALBEANSTANDUNGEN WEGEN MÄNGELN ODER FEHLERN, IST DER KÄUFER DAZU BERECHTIGT, DIE ZAHLUNGEN BEREITS GELIEFERTER WARE AUSZUSETZEN ODER ZU VERSPÄTEN, VORBEHALTLICH DES RECHTS AUF ERSTATTUNG, INFOLGE NACHWEIS DESSEN WAS UNGESCHULDET BEZAHLT WORDEN SEIN SOLLTE.

REKLAMATIONEN UND GARANTIE

ES WERDEN KEINE REKLAMATIONEN BERÜCKSICHTIGT, WENN DIESE NICHT INNERHALB 8 TAGEN NACH EINGANG DER WARE AM BESTIM- MUNGORT BEI UNS GEMELDET WERDEN. HAT DER KÄUFER FRISTGERECHT REKLAMIERT, MUSS ER DIE GESAMTE WARENLIEFERUNG DEM VERKÄUFER ZUR KONTROLLE BEREITSTELLEN; SOLLTEN ETWAIGE MÄNGEL ODER QUALITATIVE FEHLER FESTGESTELLT WERDEN, HAT DER KÄUFER NUR ANSPRUCH AUF ERSATZ DER FEHLERHAFTEN WARE, UNTER AUSSCHLUSS JEDLICHEN SCHADENSERSATZANSPRUCHES. IN KEI- NEM FALLE KANN EINE VERGÜTUNG DEN VERRECHNETEN

WARENWERT ÜBERSTIEGEN, ZUSÄTZLICH DER ENTSPRECHENDEN TRANSPORTSPESEN. DIE GARANTIE DER WARE BESCHRÄNKT SICH EINZIG AUF MATERIAL 1. WAHL; MATERIAL 2. UND 3. WAHL, BZW. ABVERKAUFWARE BLEIBEN DAVON IN JEDER HINSICHT AUSGE

SCHLOSSEN. JEDE, AUCH

TEILWEISE VERARBEITUNG DES MATERIALS, BEWIRKT EINE UNBEDINGTE ANNAHME DER GÜTER, ENTSPRECHEND DER AUS DEM BESTELLUN- GSANTRAG HERVORGEHENDEN ANGABEN.

DIE HAFTUNG DES VERKÄUFERS ERSTRECKT SICH KEINESFALLS AUF DEN VOM KÄUFER VORGESEHENEN EINSATZBEREICH UNSERER MA- TERIALIEN; SELBST DANN NICHT, WENN UNSERERSEITS RATSCHLÄGE UND ANWEISUNGEN ZUR VERLEGUNG ERTEILT WORDEN SIND. ABGE- SEHEN DER GARANTIE, WELCHE AUS DER PRODUKTDESCRIBTION IN DER AUFTRAGSBESTÄTIGUNG, AUS DEN KATALOGEN ODER ANDEREN UNTERLAGEN DES UNTERNEHMENS HERVORGEHT, KANN KEINERLEI WEITERREICHENDE PRODUKTHAFTUNG IN ANSPRUCH GESTELLT WER- DEN. AUSSERDEM WIRD JEDLICHE IMPLIZITE GARANTIE ODER EIGNUNG DES PRODUKTS FÜR EINEN BESONDEREN EINSATZBEREICH AUSGE- SCHLOSSEN UND DER KÄUFER NIMMT ZUR KENNTNIS, DASS DER VERKAUF DER PRODUKTE UNTER DER KLAUSEL „GESEHEN UND GEFALLEN“ ERFOLGT. IM FALLE DER RÜCKNAHME DER WARE,

WELCHE AUSSCHLIESSLICH INFOLGE UNSERER BEWILLIGUNG ERFOLGEN KANN, WERDEN WIR EINZIG DIE TRANSPORTKOSTEN ZU UNSEREN LASTEN

ANERKENNEN, JEDLICHE ANDERE ART VON SPESEN AUSGESCHLOSSEN.

GARANTIEVERFALL

BEI ERHALT DER WARE IST DER KÄUFER VERPFLICHTET DIESELBE EINER SORGFÄLTIGEN KONTROLLE ZU UNTERZIEHEN. FALLS BEI ÖFFNUNG DER KARTONE, IN JEDLICHER HINSICHT OFFENSICHTLICHE MÄNGEL FESTGESTELLT WERDEN, FÜR WELCHE UNSERE GARANTIE IN ANSPRUCH GENOMMEN WERDEN KANN, IST DER KÄUFER VERPFLICHTET EINE REKLAMATION EINZUREICHEN, WELCHE NUR DANN GÜLTIG SEIN WIRD, WENN DIESE INNERHALB EINES UNAUFSCHEBBAREN TERMINS VON ACHT TAGEN NACH ERHALT DER WARE, PER EINSCHREIBEBRIEF DIREKT AN UNS ADRESSIERT WIRD. NACH VERSTREICHEN DIESER FRIST, HAT DER KÄUFER JEDLICHE GEWÄHRLEISTUNG VERWIRKT, FALLS EIN MAN- GEL AUCH VON EINEM GUTACHTER ALS OFFENKUNDIG BETRACHTET WÜRD. FALLS DIE REKLAMATION VOM KÄUFER ORDNUNGSGEMÄSS EINGEREICHT WORDEN SEIN SOLLTE, IST DIESER DAZU VERPFLICHTET DIE GESAMTE WARENMENGE ZU UNSERER VERFÜGUNG ZU HALTEN; IM FALLE EINER NUR TEILWEISEN VERFÜGBARKEIT, GILT JEDLICHER GARANTIEANSPRUCH ALS VERWIRKT.

GERICHTSSTAND -ANWENDBARES RECHT BEI JEDLICHER STREITIGKEIT, WELCHE DIE LIEFERUNGEN BETRIFFT, SOWOHL SEITENS DES KÄUF- ERS ALS AUCH DES VERKÄUFERS, WIRD AUSSCHLIESSLICH ITALIENISCHES RECHT ANGEWENDET. ALS ZUSTÄNDIGE GERICHTSBARKEIT WIRD DER GERICHTSHOF IN REGGIO EMILIA BESTIMMT.

GAMBINI GROUP SI RISERVA IL DIRITTO DI APPORTARE IN QUALSIASI MOMENTO MODIFICHE O VARIAZIONI AI PRODOTTI PRESENTI IN QUESTO CATALOGO.

GAMBINI GROUP RESERVES THE RIGHT TO CHANGE THE PRODUCTS PRESENTED IN THIS CATALOGUE AT ANY TIME.

NON SI ACCETTANO RECLAMI PER I MATERIALI POSTI IN OPERA.

NO COMPLAINTS WILL BE ACCEPTED FOR MATERIAL AFTER LAYING.

COORDINAMENTO:
UFFICIO MARKETING GAMBINI GROUP

FINITO DI STAMPARE:
FEBBRAIO 2023

GAMBINI TILE ON TIME - BRAND OF:
GAMBINI GROUP S.p.A.

VIA RADICI IN PIANO, 675 - 41049 SASSUOLO (MO) . ITALY
PH. +39 0536 995711 . FAX +39 0536 905042-807182



Stay connected with our social networks:



@Gambinitile /Gambini group Ceramiche



@Gambinigroup



@Gambinigroup s.p.a



Gambinigroup s.p.a



WWW.GAMBINITILE.COM

GAMBINI GROUP
divisione Gambini Green



Idee eco sostenibili che partono dal cambiamento più importante: noi stessi.

2023 Inizio di un nuovo progetto di eco sostenibilità per tutto il gruppo che introdurrà innovazioni tecnologiche per la produzione e gestione delle materie prime, al fine di un ampio risparmio energetico e alla creazione di un'economia circolare produttiva.

GAMBINI GROUP – Gambini Green division

Eco friendly visions starting from the most important change: ourselves.

2023: A new project of eco-sustainability for all the Group, introducing technological innovations in the production and in the source of raw materials fields, with a view to a wide energy saving and to a creation of a circular and productive economy.



www.gambinitile.com